



# **IQ Power™ Fantom Wide Ionizing Blower**

---

## **INSTALLATION AND OPERATING INSTRUCTIONS**

# TABLE OF CONTENTS

---

|  |           |
|--|-----------|
| <b>1. SAFETY WARNINGS .....</b>              | <b>1</b>  |
| <b>2. DESCRIPTION .....</b>                  | <b>2</b>  |
| <b>3. SPECIFICATIONS .....</b>               | <b>3</b>  |
| <b>4. INSTALLATION .....</b>                 | <b>4</b>  |
| Position and Mounting.....                   | 4         |
| Electrical Connections .....                 | 4         |
| Connection to User Interface.....            | 5         |
| Connection to IQ Power Control Station.....  | 7         |
| System Configuration .....                   | 7         |
| Set-Up .....                                 | 10        |
| <b>5. OPERATION .....</b>                    | <b>12</b> |
| Indicator Lights .....                       | 12        |
| Operation with IQ Power Control Station..... | 13        |
| <b>6. MAINTENANCE.....</b>                   | <b>14</b> |
| Ionizing Emitter Points.....                 | 14        |
| Air Intake Filter .....                      | 14        |
| Ionizer Module .....                         | 14        |
| Ion Balance.....                             | 15        |
| <b>7. TROUBLESHOOTING.....</b>               | <b>16</b> |
| Operational Check.....                       | 16        |
| <b>8. PARTS AND ACCESSORIES .....</b>        | <b>17</b> |
| <b>9. WARRANTY AND SERVICE.....</b>          | <b>18</b> |

# 1. SAFETY WARNINGS

---

## PLEASE READ INSTRUCTIONS COMPLETELY BEFORE STARTING INSTALLATION

### ALL INSTALLATION AND TROUBLESHOOTING OPERATIONS MUST BE PERFORMED BY QUALIFIED TECHNICAL PERSONNEL

This instruction manual uses symbols to identify dangerous situations as follows:



**NOTE** – Statements identified with NOTE indicate precautions necessary to avoid potential equipment failure.



**CAUTION** – Statements identified with CAUTION indicate potential safety hazards.

**ATTENTION** – Les déclarations identifiées avec ATTENTION indiquent des dangers potentiels pour la sécurité.



**WARNING** – Statements identified with WARNING indicate potential serious injury hazards.

**AVERTISSEMENT** – Les déclarations identifiées avec AVERTISSEMENT indiquent un risque de blessures graves.



**NOTE** – This equipment must be correctly installed and properly maintained. Adhere to the following notes for safe installation and operation:

1. Read instruction manual before installing or operating equipment.
2. Only qualified service personnel are to perform installation and repairs.
3. All equipment must be properly grounded, including the machine frame to which the equipment is mounted.
4. Turn off input power to unit before connecting or disconnecting other equipment.
5. Do not operate system in close proximity to flammable liquids.
6. Do not use standard Ethernet cables with IQ Power Systems.



**NOTE** – Do not attempt to operate at voltages other than those specified.



**NOTE** – Do not allow dust, dirt or debris to block or obstruct air flow inlets or outlets.



#### **CAUTION – Electric Shock Hazard**

Electrical installation and repairs must be performed by a skilled electrical engineer according to the applicable national and local regulations. The equipment must be properly grounded. Grounding is required to ensure safe and proper operation and to prevent electrical shocks upon contact.

#### **AVERTISSEMENT– Risque De Choc Électrique**

L'installation et le service électrique doivent être effectuées par un électricien qualifié conformément aux réglementations locales et nationales. Le matériel doit être correctement mis à la terre. Mise à la terre est nécessaire pour assurer un fonctionnement sûr et correct et pour éviter les chocs électriques en cas de contact.



#### **WARNING – Fire Hazard**

Keep the unit dry. Do not operate the unit in flammable or explosive environments.

#### **AVERTISSEMENT – Risque d'incendie**

Gardez l'appareil au sec. Ne pas utiliser l'appareil dans des environnements inflammables ou explosifs.

## 2. DESCRIPTION

---

Simco-Ion's IQ Power Fantom Wide Blower is a highly reliable, extended-range ionizing air blower designed for static elimination in many industrial applications. Its high power fan covers a large area with balanced ionization for rapid static neutralization. The Fantom is a self-contained unit that includes variable speed fan control and closed-loop ion output and ion balance control. The built-in emitter point cleaner provides manual, automatic, or remote cleaning to remove dust buildup from the emitter points. This ensures full output of ionized air.

The Fantom features a user interface and indicators to continuously monitor performance. It also supports connection to the IQ Power Control Station for the ultimate in remote monitoring and control. Cables for interconnection with a Control Station are available by calling Simco-Ion customer service (800) 203-3419 (refer to Section 8, Parts and Accessories).



### 3. SPECIFICATIONS

|   |   |                                 |
|---|---|---------------------------------|
| <b>Input Power</b>                            | 120 VAC, 50/60 Hz, 2A (fan speed high)<br>Fuse: 3A time delay ¼" x 1¼"<br>230 VAC, 50/60 Hz, 1A (fan speed high)<br>Fuse: 1.5A time delay ¼" x 1¼"  |                                 |
| <b>Operating Temperature</b>                  | 32-100°F [0-38°C]   |                                 |
| <b>Operating Humidity</b>                     | 70% RH max, no condensing (dewing) permissible  |                                 |
| <b>Air Volume*</b>                            | 600 cfm [18m <sup>3</sup> /min] max   |                                 |
| <b>Air Filter</b>                             | 11.3" x 25.8" [287 x 655 mm] polyurethane foam 20 ppi   |                                 |
| <b>Air Speed*</b>                             | 1600 fpm @ 1 ft. [8.1 m/s @ 0.3m]<br>1300 fpm @ 2' [6.6 m/s @ 0.6m]<br>1000 fpm @ 3' [5.1 m/s @ 0.9m]<br>900 fpm @ 4' [4.6 m/s @ 1.2m]  | Fan speed high on centerline    |
| <b>Noise Level</b>                            | 64 dB @ 2' [0.6m], fan speed high   |                                 |
| <b>Discharge Time*</b>                        | 0.4 sec @ 1' [0.3m]<br>0.9 sec @ 2 ft [0.6m]<br>1.8 sec @ 3 ft [0.9m]<br>2.3 sec @ 4 ft [1.2m]<br>3.3 sec @ 5 ft [1.5m]<br>4.5 sec @ 6 ft [1.8m]<br>6.5 sec @ 8 ft [2.4m]<br>9.0 sec @ 10 ft [3.0m] | Fan speed high, 1000-100V (typ) |
| <b>Mounting</b>                               | 3.94" x 20.28" [100 x 515 mm] mounting centers with 10-32 screws  |                                 |
| <b>Enclosure</b>                              | Steel, blue epoxy powder coated   |                                 |
| <b>Dimensions</b>                             | 12.75"L x 26"W x 8"H [324 x 660 x 204 mm]   |                                 |
| <b>Weight</b>                                 | 31 lb [14 kg]   |                                 |
| * Derate values ~20% when operating at 50 Hz. |   |                                 |

## 4. INSTALLATION

### Position and Mounting

For maximum effectiveness, position the Fantom Wide Blower as close as possible to the charged surface to be neutralized. Direct the air stream longitudinally, and in the same direction as, the target material movement to maximize the time the charged surface remains in the air stream. Ensure that the ionized air stream covers the entire target surface, and that the material to be neutralized is not in direct contact with a background surface (such as a roller or laying on a tabletop). For best results, the material to be neutralized should be in free air.

The Fantom can be placed on any flat, level surface. It can also be secured using the (4) large truss head screws on the bottom of the unit. The (4) large truss head screws thread directly into the internal fan frame, providing a secure mounting.

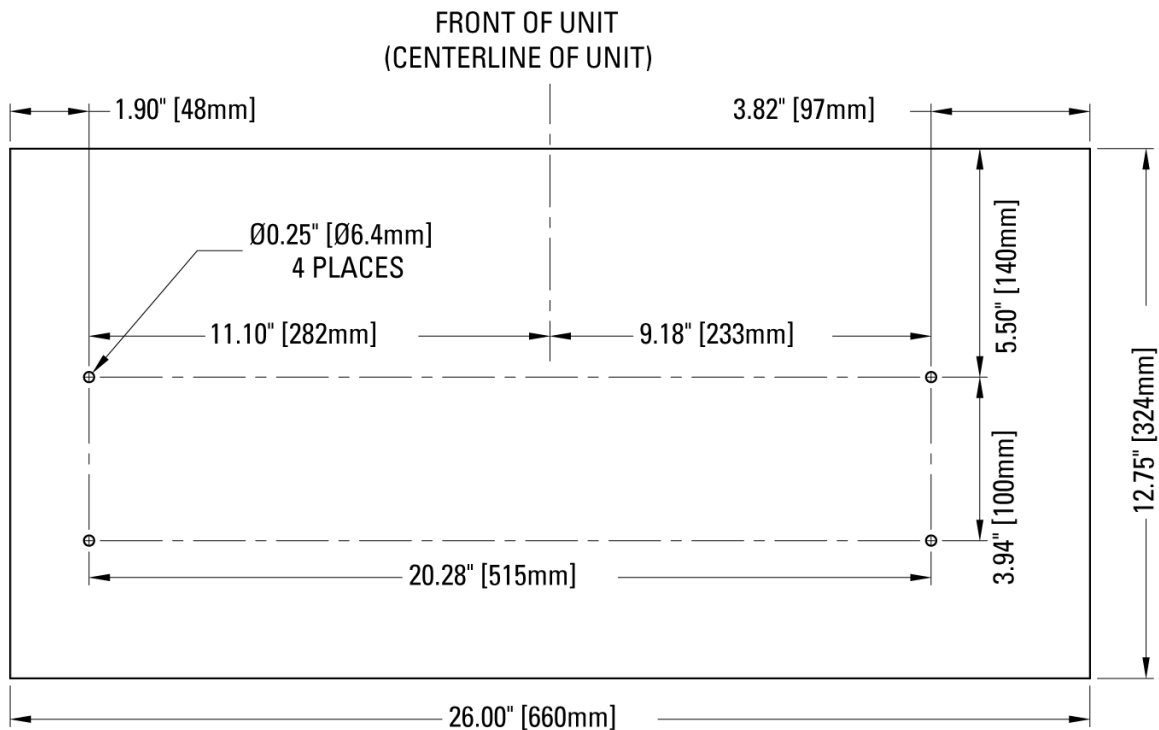

Figure 1. Hole Pattern on Bottom of Unit (top view of unit)

### Electrical Connections

Depending on the model, the Fantom Wide Blower requires 120 VAC or 230 VAC, 50/60 Hz. Connect line cord to a grounded receptacle. If an extension cord is used, it must be a 3-wire type providing electrical ground to the unit.



**NOTE** – Do not attempt to operate at voltages other than those specified.



#### **CAUTION – Electric Shock Hazard**

Electrical installation and repairs must be performed by a skilled electrical engineer according to the applicable national and local regulations. The equipment must be properly grounded. Grounding is required to ensure safe and proper operation and to prevent electrical shocks upon contact.

#### **AVERTISSEMENT – Risque De Choc Électrique**

L'installation et le service électrique doivent être effectués par un électricien qualifié conformément aux réglementations locales et nationales. Le matériel doit être correctement mis à la terre. Mise à la terre est nécessaire pour assurer un fonctionnement sûr et correct et pour éviter les chocs électriques en cas de contact.

## Connection to User Interface

The User Interface provides connection to the alarm relay, the ability to remotely activate the point cleaner, and the ability to remotely place the unit in standby. The User Interface also provides a current limited source of +24 VDC for user signaling purposes.

The connections for the User Interface are:

- Terminal 1: +24 VDC Output (100 mA max)
- Terminal 2: Fault Relay N.C.
- Terminal 3: Fault Relay Com.
- Terminal 4: Fault Relay N.O.
- Terminal 5: Clean Logic Input
- Terminal 6: Standby Logic Input
- Terminal 7: Ground

The connections for the User Interface is a 7-position pluggable header with screw terminals. The connector accepts 16-26 AWG solid or stranded wire with a strip length of ¼" [7 mm]. To install wires into the connector, push stripped wire fully into the square hole on connector and tighten securely with a small flat-blade screwdriver. The terminal block header is plugged into the User Interface, located in a protective connector bay, on the side of the Phantom Wide Blower.

## Outputs

The Fault Relay N.C. contact “makes” to indicate normal operation. The N.O. contact “makes” to indicate an alarm. The N.O. contact also “makes” when power is removed from the Phantom or the Phantom is turned off.

The relay contacts are rated for a maximum of 1 amp at 24 volts, with a resistive load.

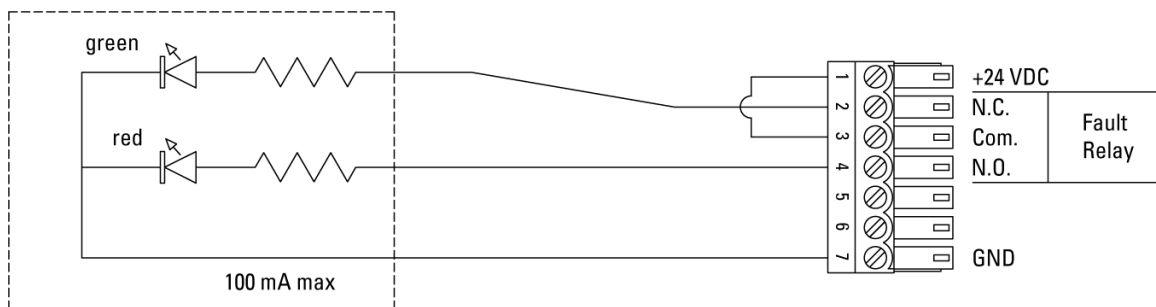

Figure 2. User Interface Relay Output (Typical Indicator Schematic)

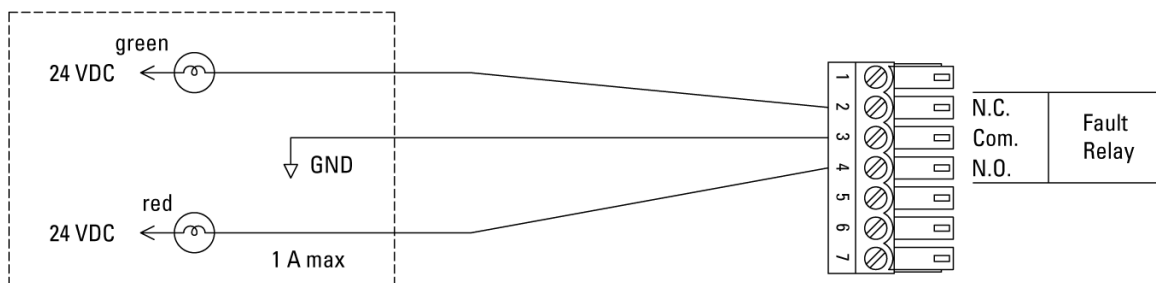

Figure 3. User Interface Relay Output (Typical Light Tree Schematic)

In a typical indicator or light tree application:

- The green light indicates the unit is operating correctly or in standby.
- The red light indicates the unit in fault or not powered.

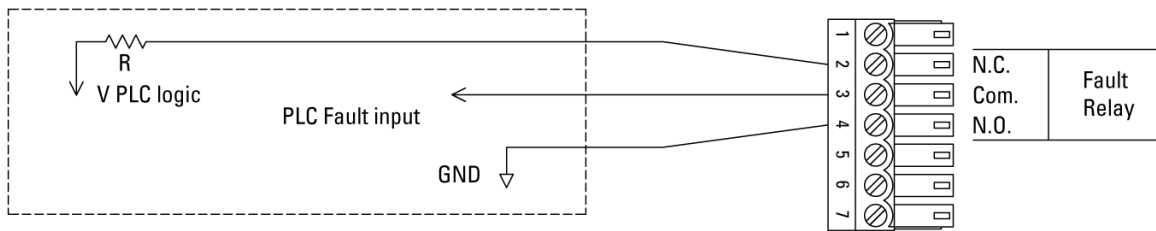

Figure 4. User Interface Relay Output (Typical PLC Schematic)

In a typical PLC application:

- The PLC input will be held high during normal operation or in standby.
- The PLC input will be low on fault or if the unit is not powered.

**Inputs**

Two inputs are available at the User Interface. The automatic point cleaner may be activated with a momentary application of voltage to terminal 5. The unit can be placed and held in standby mode with the application of a voltage to terminal 6.

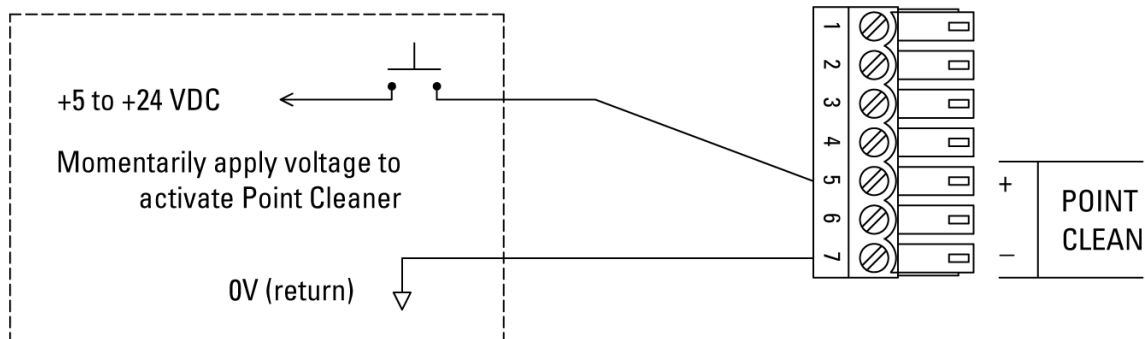

Figure 5. User Interface Point Cleaner (Schematic)

A momentary application of +5 to +24 volts DC to terminal 5 (terminal 7 being the return, 0 volts) will activate an automatic point cleaning cycle. If the blower fan is operating (unit not in standby), the fan will be de-energized and allowed to come to a stop (approximately 4 seconds). The automatic point cleaner will cycle three times (approximately 6 seconds). If the unit was not in standby, the blower fan will resume operation.

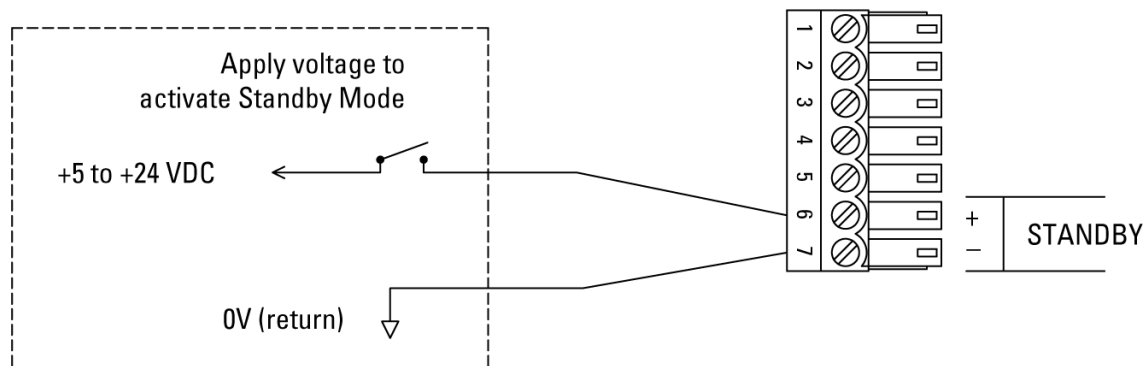

Figure 6. User Interface Standby (Schematic)

A continuous application of +5 to +24 volts DC to terminal 6 (terminal 7 being the return, 0 volts) will place the unit in standby mode. In standby the blower fan and ionization power supplies are de-energized. It takes approximately five seconds for the unit to resume operation after the voltage is removed from terminal 6.

## Connection to IQ Power Control Station

Two communication ports are available on the Fantom Wide Blower, COMM1 and COMM2. These communication ports allow connection to an IQ Power Control Station. Either port may be used for connection. COMM1 provides an M12 connector for round cable and COMM2 provides an RJ-45 connector for modular cable. Cables of various lengths are available, see Section 8, Parts and Accessories.



**NOTE** – DO NOT USE standard Ethernet cables with IQ Power systems. Avoid permanent equipment damage by using only Simco-Ion modular cables. (Refer to Section 8, Parts and Accessories).

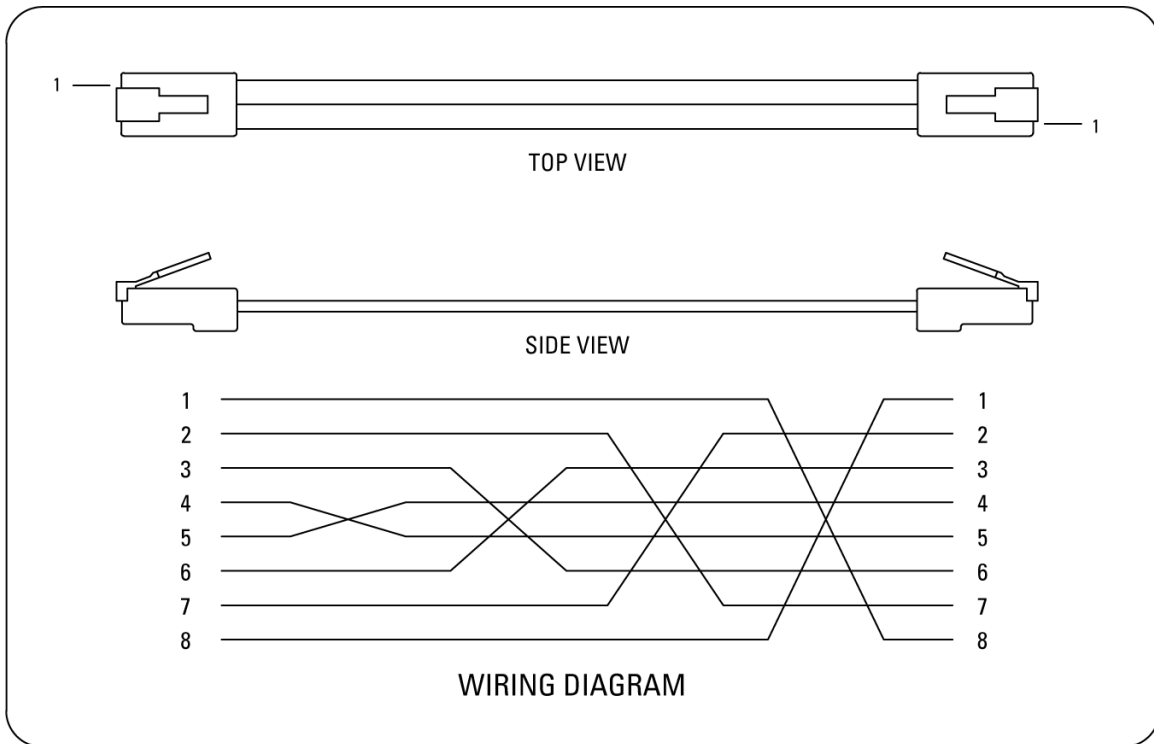

Figure 7. IQ Power Crossover Modular Cable (black)

Connection with a Control Station allows two-way digital communication with the Fantom Wide Blower. The Control Station is able to display a variety of operating parameters and settings in the Fantom Wide Blower. If a Control Station is connected to the Fantom, but the Fantom is not powered or turned off, the Control Station will still be able to display the fixed settings in the Fantom Wide Blower.





**NOTE** – When a Fantom Wide Blower is connected to a Control Station, the Fantom still requires connection to line voltage to operate.

## System Configuration

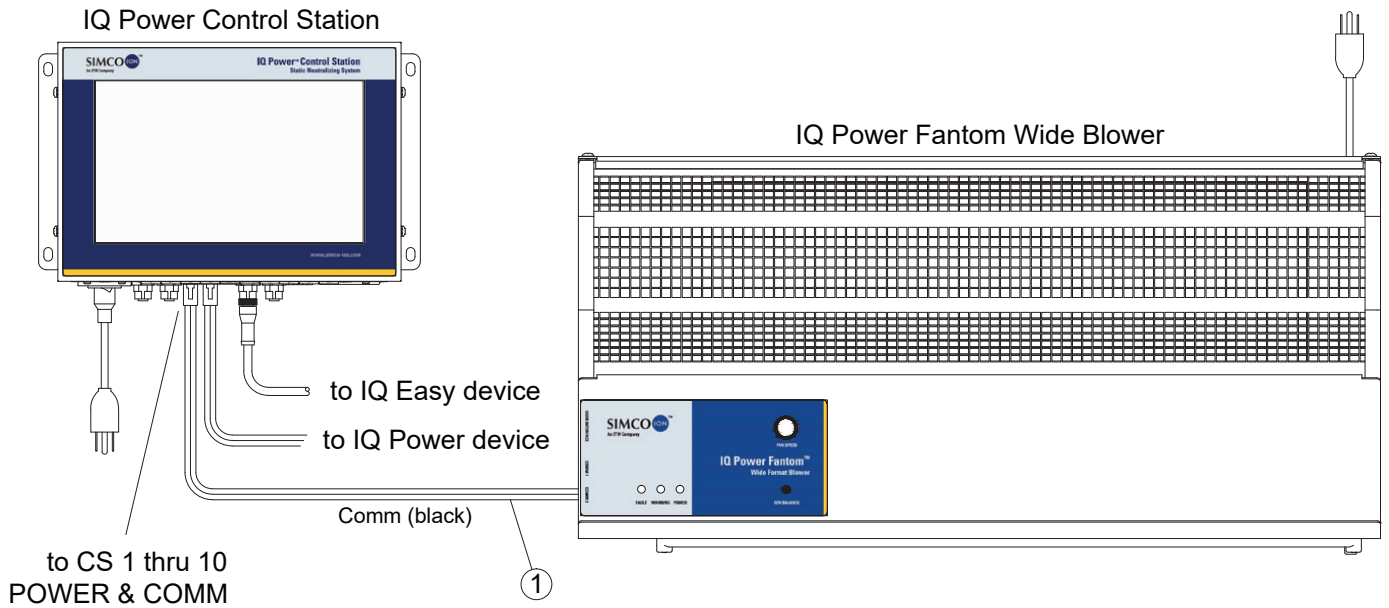
The Fantom Wide Blower and related Control Station / IQ Easy Sensor Bar can be configured in a variety of ways. When an ionizing blower is paired with a static sensor bar, the pair is considered a single device by the Control Station. The following figures each illustrate a fundamental configuration with specific equipment. Fundamental configurations may be combined on a system to meet the particular needs of the application.

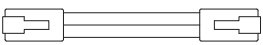

**Comm / Data Cable Construction**

① Crossover Wired   Reference color black

**DO NOT USE** standard Ethernet cables.

See Section 8 Parts and Accessories for available cable lengths and part numbers.

Alternate cable that may be used to connect Fantom to CS DEV1 thru DEV6.

M12 to M12 Connector Cable

Control Station End  Straight (Fantom End)

Figure 8. IQ Power Connections (Fantom to Control Station)



NOTE: when IQ Power Phantom and IQ Easy Modular Sensor share the same address they pair for CLFB operation.

Comm / Data Cable Construction

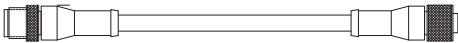
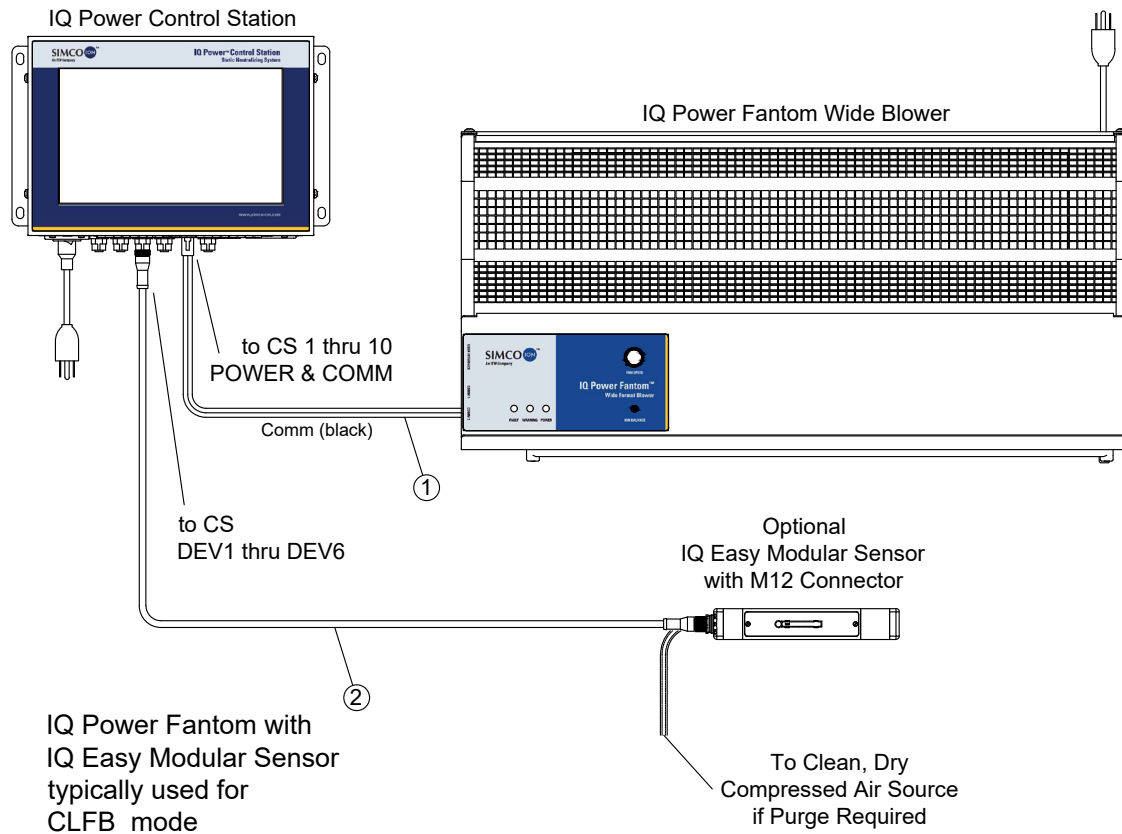
① Crossover Wired  Reference color black

**DO NOT USE** standard Ethernet cables.  
See Section 8 Parts and Accessories for available cable lengths and part numbers.

M12 to M12 Connector Cable Construction

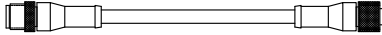
② Control Station End  Straight (Sensor End)

Control Station End  Right Angle (Sensor End)

Figure 9. IQ Power Connections (Fantom and IQ Easy Sensor to Control Station)



IQ Power Phantom with IQ Easy Modular Sensor typically used for CLFB mode

NOTE: when IQ Power Phantom and IQ Easy Modular Sensor share the same address they pair for CLFB operation.

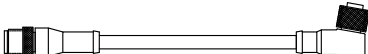
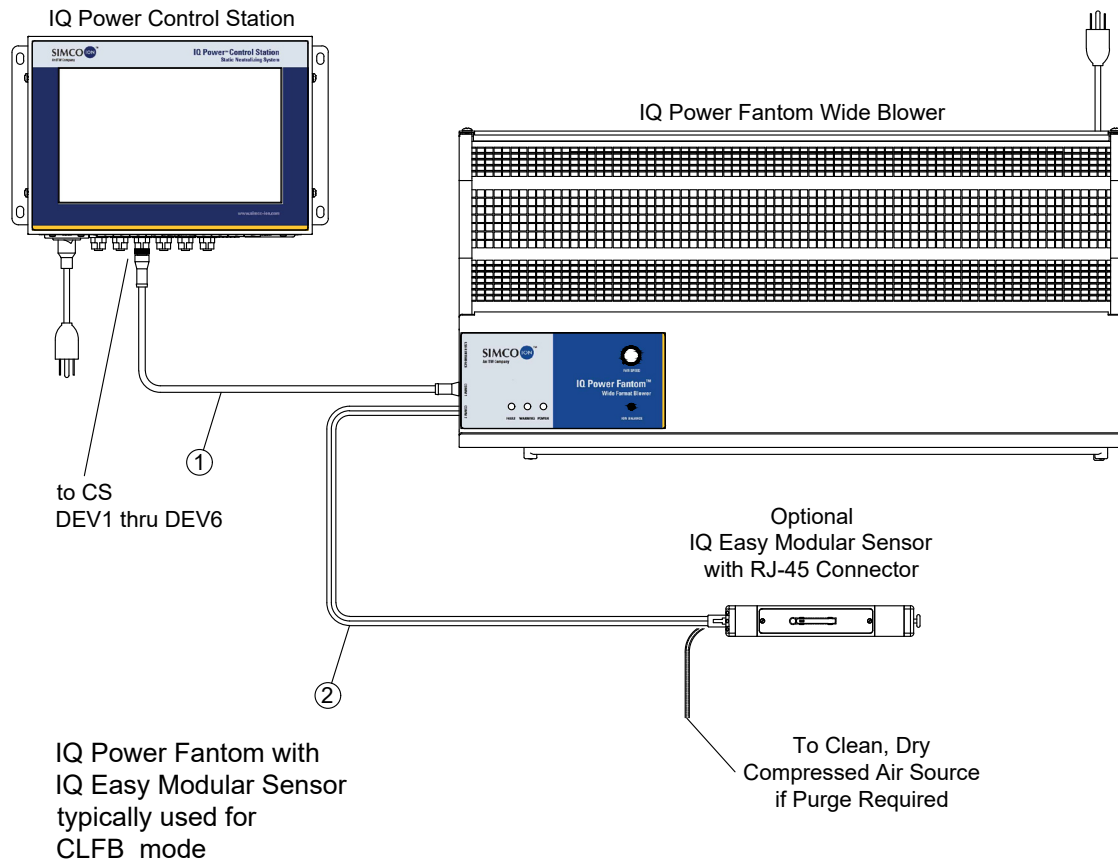
M12 to M12 Connector Cable Construction

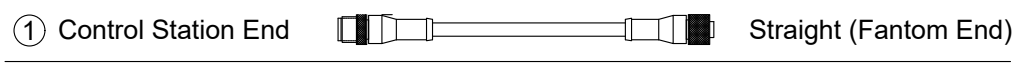

Comm / Data Cable Construction

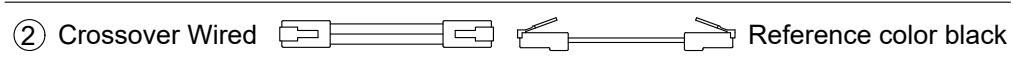

DO NOT USE standard Ethernet cables.  
See Section 8 Parts and Accessories for available cable lengths and part numbers.

Figure 10. IQ Power Connections (Fantom to IQ Easy Sensor and Control Station)

**Set-Up**

If the Fantom Wide Blower is operating free standing (without connection to a Control Station) set up is simply adjusting the air flow on target and adjusting the blower fan speed if necessary.

When connected to a Control Station, a variety of information can be checked and operating parameters may be set for the Fantom.

**NOTE** – If the Fantom is connected to a Control Station but the Fantom power switch is off or power disconnected, the Control Station will display a fault and basic information for the unit.

To edit or select an operating parameter, tap on pencil icon to right of parameter description.

**Device Name:** A user editable name to identify the specific device (14 character).

**Device Type:** A fixed description for the device type (e.g., Ionizing air blower)

**Operation Mode:** A user selectable operating mode for the ionizing air blower (Fixed, Manual Narrow, Manual Wide, CLFB).

- **Fixed** - Ionization balance set to zero using the Ion Balance control on unit (default factory setting).
- **Manual Narrow** - Allows fine manual control of the ion balance over a narrow range using the IQ Power Control Station. This mode of operation would only be selected where the material to be neutralized exhibited consistent charging of one polarity. An electrostatic field meter would be used to assure neutralization during set-up.
- **Manual Wide** - Allows coarse manual control of the ion balance over a wide range using the IQ Power Control Station. This mode of operation would only be selected where the material to be neutralized exhibited a challenging and consistent charging of one polarity. An electrostatic field meter would be used during set-up.
- **CLFB** - Closed-loop Feedback, requires pairing with a downstream IQ Easy Modular Sensor through the IQ Power Control Station. The sensor detects any voltage imbalance on the material to be neutralized, then transmits this information to the ionizing blower. The ionizing blower makes incremental changes to the balance setting until material charges are minimized.

**Ionization Output:** The ionization level, in percent.

**Ionization Current:** The ionization level in terms of microamps for both positive and negative ionization.

**Paired Sensor:** The specific sensor bar to be used with this ionizing blower for closed loop feedback control. The default is “none”; a specific sensor bar must be selected to enable closed loop feedback control. The specific sensor bar is selected by choosing its “device name”. The sensor bar **MUST** be located where it will monitor the material being neutralized.

**Balance:** A ratio of input power supplied to the high voltage power supplies that related to ion balance. In Balanced and CLFB modes this is a display only and non-editable. The Balance number may only be user adjusted in the Manual modes.

**Data Logging:** An on/off setting to enable data logging for this device. The factory default is off.

**Firmware Version:** The firmware revision in the ionizing blower.

## 5. OPERATION

Turn unit on with main power switch, located adjacent to the line cord. After the Fantom goes through an automatic point cleaning cycle, it will begin operating. The fan speed may be adjusted with the fan speed adjustment knob. Use the highest airspeed the application allows. This insures quick discharge times and maximum coverage.

### Indicator Lights

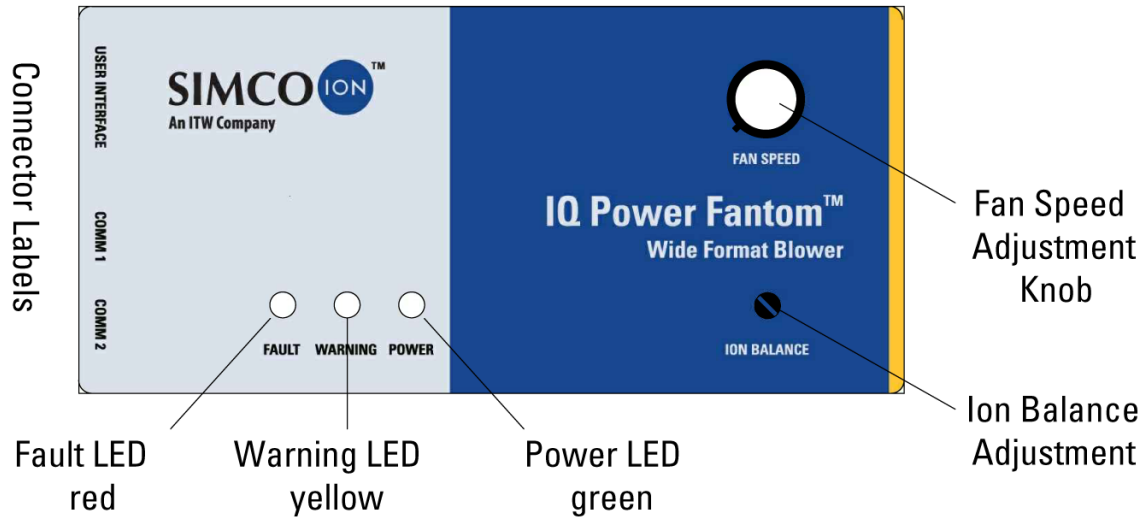

Figure 11. Fantom Indicator Lights and Adjustments

Two sets of indicator lights are on the Fantom Wide Blower. One set is visible through the unit face label. The second set is located in the connector bay, above the User Interface. This set is visible from the side of the unit.

### Power

- A steady green Power light indicates the unit is powered and active.
- A blinking green light indicates the unit is in standby.
- A rapidly flashing green light indicates the unit has received a command from the Control Station. The rapid flashing only lasts for several seconds.

### Warning

- A steady yellow Warning light indicates the internal monitoring and control circuits are approaching the limits for normal operation (the unit is still in closed-loop control). The unit may need to be cleaned or otherwise serviced.

### Fault

- A steady red Fault indicates the internal monitoring and control circuits have exceeded limits for normal operation (the unit is no longer in closed-loop control).
- A steady red Fault light may also indicate a failure of a high voltage power supply or control circuitry.
- A steady red Fault light is also used to indicate the Fantom is connected to a Control Station and AC line voltage is not applied or the Fantom power switch is off.

## Operation with IQ Power Control Station

Operation of the Fantom Wide Blower can be controlled through the IQ Power Control Station. In operation, a device icon appears on the Control Station Home Page. Tapping on the device icon opens a Summary page containing information about the Fantom ionizing blower and sensor bar (if paired). More detailed information and user editable parameters are available through device tabs on the Control Station screen. For more information on these details see Set Up section in this document.



**NOTE** – When a Fantom Wide Blower is connected to a Control Station, the Fantom still requires connection to a line voltage to operate.

## 6. MAINTENANCE

---

### Ionizing Emitter Points

1. Dust or dirt on the ionization points will reduce effectiveness of the blower. Ionization points must be cleaned periodically to prevent deposits from accumulating.
2. Simply turn OFF and back ON. The automatic point cleaner will cycle three times to clean the ionizing points. If the automatic point cleaner should become inoperative, there is a Point Cleaner button adjacent to the ionized air outlet. Push the button several times to clean the ion emitter points.
3. Frequency of cleaning should be at least once monthly, or as determined by inspections based on operating conditions.

### Air Intake Filter

1. Filter cleaning or replacement frequency depends upon the cleanliness of the operating environment. Inspect filters weekly, clean or replace as required.
2. Turn the unit OFF and remove air filter from intake.
3. The air filter is open cell polyurethane. It may be cleaned with mild soap and water. Rinse thoroughly and allow to dry before reinstalling.
4. To install air filter, place over intake grille. Tuck edges of air filter in recess around perimeter of intake grille.

### Ionizer Module



#### **CAUTION – Risk of Injury**

Turn off and disconnect unit from line voltage before removing ionizer module. Use care handling ionizer module, puncture hazard, sharp pins are present.

#### **MISE EN GARDE – Risque de blessure**

Éteindre et débrancher l'unité de la tension secteur avant de retirer le module ioniseur. Manipuler le module ioniseur avec précaution, risque de piqûre, broches pointues présentes.

1. Turn unit OFF.
2. Loosen (4) screws located at corners of ionized air outlet. The screws are captive and will remain with ionizing module.
3. Remove ionizing module. The side opposite the point cleaner button contains electrical connectors. It may be necessary to grasp this side and rock the ionizing module gently to disconnect the connectors.
4. Handle the ionizing module with care. The ion emitters are sharp pins that present a puncture hazard.
5. Dirt and debris may be brushed or vacuumed from the ionizing module, or the ionizing module may be replaced.
6. To install the ionizing module, line the Point Cleaner hole with the point cleaner button and insert module into unit.
7. Secure the ionizer module with the (4) screws at the corners of ionized air outlet.
8. Press Point Cleaner button and make sure it returns freely to check for proper operation of the point cleaner.

## **Ion Balance**

1. A closed-loop electronic balancing circuit in the blower controls the output ration of negative to positive ions. The circuit is preset at the factory and normally requires no further adjustment.
2. Balance may be evaluated using a charged plate monitor such as the Simco-Ion CPM. The plate should be placed at the typical operating distance for testing and adjustment. Static charges in the vicinity of measurement will affect reading, remove or neutralize static charges in the vicinity before taking ion balance measurements.
3. The balance adjustment potentiometer is accessible through a small opening on the face label of the Fantom. Using a flat-blade screwdriver, carefully adjust the potentiometer until the charged plate monitor indicates “zero”.

## 7. TROUBLESHOOTING



**NOTE** – Only qualified service personnel are to perform troubleshooting tasks.



### **CAUTION – Electric Shock Hazard**

Do not troubleshoot high voltage components with power supply energized. Disconnect input power before troubleshooting. Troubleshooting must be performed by a qualified service person.

### **ATTENTION – Risque De Choc Électrique**

Ne pas faire de dépannage des composantes de haute tension avec alimentation sous tension. Couper l'alimentation électrique avant le dépannage. Le dépannage doit être effectué par une personne qualifiée.

### **Operational Check**

1. Rub a small strip of plastic film until a static charge is developed (cellophane works well). The charge can either be measured with an electrostatic fieldmeter or will be evidenced by the film's attraction to a grounded metal surface.
2. Pass the film in front of the blower for five seconds at a distance of one foot. Check for any charge remaining on the film as in step 1.
3. If the static charge has been neutralized, then the device is working properly.

If equipment fails to function properly, contact Simco-Ion Customer Service or your local Simco-Ion Representative.



**NOTE** – Never use a “spark test” to check operation. The ionizing circuit design of the Fantom makes the “spark test” inconclusive and arcing may damage the unit.

| PROBLEM  | CAUSE   | SOLUTION   |
|--|---|--|
| Fantom not working; no indicators, fan not running | Power not on  | Turn on power switch near line cord  |
|  | Line voltage not supplied   | Check line voltage and connections   |
|  | Blown fuse  | Check fuse and replace with proper value / type                                |
| Warning indicator is lit                           | Unit approaching control limits   | Clean ion emitters with the built-in point cleaner                             |
|  |   | Remove the ionizing module and thoroughly clean or replace the ionizing module |
| Fault indicator is lit                             | Unit exceeding control limits   | Clean ion emitters with the built-in point cleaner                             |
|  |   | Remove ionizing module and thoroughly clean or replace ionizing module         |
|  | Fantom connected to Control Station and Fantom AC power is off                      | Apply line voltage to Fantom and turn Fantom power switch on                   |
|  | Failure of high voltage power supply or control circuitry                           | Return unit to factory authorized repair facility                              |
| Communications failure                             | Incorrectly wired cable (check against cable illustrations in Installation section) | Replace or repair cable  |
|  | Connector problem   | Check connectors for damage and proper seating                                 |

## 8. PARTS AND ACCESSORIES

| Part Description  | Part Number |
|---|-------------|
| Fantom Wide Blower (120 VAC input)  | 4016993     |
| Fuse, 3 Amp, ¼" x 1-1/4", Time Delay  | 4610708     |
| Fantom Wide Blower (230 VAC input)  | 4016994     |
| Fuse, 1.5 Amp, ¼" x 1-1/4", Time Delay  | 4610133     |
| Air Filter Kit (package of 10), Open Cell Polyurethane for Fantom Blower  | 5051958     |
| Connector Kit, Fantom User Interface (7-position)   | 5051855     |
| Ionizer Module, Fantom Blower   | 5051959     |
| Modular Cable (RJ-45 to RJ-45, IQ Power 8-conductor, crossover wired) for use between Control Station and Fantom Blower (Ref. Figure 10 & 11) DO NOT USE Standard Ethernet Cables |             |
| 0.91 meter [3 foot] black   | 4520785     |
| 2.13 meter [7 foot] black   | 4520786     |
| 4.27 meter [14 foot] black  | 4520787     |
| 7.62 meter [25 foot] black  | 4520784     |
| 15.24 meter [50 foot] black   | 4520844     |
| 30.48 meter [100 foot] black  | 4520845     |
| Cable (M12 connectors at both ends) for use between Control Station and Fantom or Sensor Bar (Ref. Figure 11 & 12)  |             |
| 5 meter [16.4 foot] Straight / Straight M12 Connector   | 5051791     |
| 10 meter [32.8 foot] Straight / Straight M12 Connector  | 5051792     |
| 20 meter [65.6 foot] Straight / Straight M12 Connector  | 5051793     |
| 30 meter [98.4 foot] Straight / Straight M12 Connector  | 5051794     |
| Cable (M12 connectors at both ends) for use between Control Station and Sensor Bar (Ref. Figure 11)   |             |
| 5 meter [16.4 foot] Straight / Right Angle M12 Connector  | 5051796     |
| 10 meter [32.8 foot] Straight / Right Angle M12 Connector   | 5051797     |
| 20 meter [65.6 foot] Straight / Right Angle M12 Connector   | 5051798     |
| 30 meter [98.4 foot] Straight / Right Angle M12 Connector   | 5051799     |
| Cable (RJ-45 to straight M12 connector) for use between Fantom and Sensor Bar (Ref. Figure 12)  |             |
| 4.57 meter [15 foot] Straight M12 Connector   | 5051840     |
| 9.14 meter [30 foot] Straight M12 Connector   | 5051844     |
| Cable (RJ-45 to right angle M12 connector) for use between Fantom and Sensor Bar (Ref. Figure 12)   |             |
| 4.57 meter [15 foot] Right Angle M12 Connector  | 5051841     |
| 9.14 meter [30 foot] Right Angle M12 Connector  | 5051845     |

## 9. WARRANTY AND SERVICE

---

This product has been carefully tested at the factory and is warranted to be free from any defects in materials or workmanship. Simco-Ion will, under this warranty, repair or replace any equipment which proves, upon our examination, to have become defective within one year from the date of purchase.

The equipment being returned under warranty should be shipped by the purchaser to Simco-Ion, 2257 North Penn Road, Hatfield, PA 19440, transportation prepaid and insured for its replacement cost. Prior to returning any goods for any reason, contact Simco-Ion Customer Service at 215-822-6401 for a Return Authorization Number (RMA). This number must accompany all returned items.

This warranty does not apply when the equipment has been tampered with, misused, improperly installed, altered, has received damage through abuse, carelessness, accident, connection to improper line voltage, or has been serviced by anyone other than an authorized factory representative.

The warranty does not apply when Simco-Ion parts and equipment have been energized by other than the appropriate Simco-Ion power supply or generator, or when a Simco-Ion power supply or generator has been used to energize other than Simco-Ion parts and equipment. Simco-Ion makes no warranty, expressed or implied, nor accepts any obligation, liabilities, or responsibility in connection with the use of this product other than the repair or replacement of parts stated herein.

Information in this publication supersedes that in all previous published material. Specifications are subject to change without notice.

**Simco-Ion**

2257 North Penn Road  
Hatfield, PA 19440

(215) 822-6401

(800) 203-3419

[www.simco-ion.com](http://www.simco-ion.com)

[customerservice@simco-ion.com](mailto:customerservice@simco-ion.com)

© 2025 Simco-Ion. Printed in the U.S.A.