



IQ Power™ HL Sensor

INSTALLATION AND OPERATING INSTRUCTIONS

TABLE OF CONTENTS

1. SAFETY WARNINGS	1
2. DESCRIPTION	3
3. SPECIFICATIONS	4
4. INSTALLATION	5
Unpacking	5
Mechanical Installation	5
Intrinsic Safety Barriers.....	7
Sensor Interface	7
Electrical Connections	8
Purge Gas	11
Sensor Number.....	11
Set Up.....	11
5. OPERATION	13
6. MAINTENANCE	14
Cleaning	14
Calibration.....	14
7. TROUBLESHOOTING	15
8. PARTS AND ACCESSORIES	16
9. WARRANTY AND SERVICE	17

1. SAFETY WARNINGS

Simco-Ion recommends that these instructions be read completely before installation or operation is attempted. Failure to do so could result in personal injury and/or damage to the equipment.



NOTE – Statements identified with NOTE indicate precautions necessary to avoid potential equipment failure.



CAUTION – Statements identified with CAUTION indicate potential safety hazards.

ATTENTION – Les déclarations identifiées avec ATTENTION indiquent des dangers potentiels pour la sécurité.



WARNING – Statements identified with WARNING indicate potential serious injury hazards.

AVERTISSEMENT – Les déclarations identifiées avec AVERTISSEMENT indiquent un risque de blessures graves.



NOTE – This equipment must be correctly installed and properly maintained. Adhere to the following notes for safe installation and operation:

1. Read instruction manual before installing or operating equipment.
2. Only qualified service personnel are to perform installation and repairs.
3. All equipment must be properly grounded, including machine frame to which the equipment is mounted.
4. Disconnect input power before connecting or disconnecting any equipment.



NOTE – SENSITIVE ELECTRONICS: Risk of equipment damage.

- Do not electrically discharge to sensor assembly.
- Sensor must be connected to power supply in presence of charged materials.



NOTE – SENSITIVE ELECTRONICS: Risk of equipment damage.

- Avoid sharp blows to sensor assembly.
- Dropping sensor may cause damage to sensors.



CAUTION – Installation must be in accordance with the National Electric Code (NEC) or applicable government, state, province or local regulations

ATTENTION – L'installation doit être en conformité avec le Code national de l'électricité (NEC) ou le gouvernement applicable , l'état , la province ou suivant les réglementations locales.



WARNING – Substitution of components may impair intrinsic safety. (Refer to Control Drawing, Figure 3).

AVERTISSEMENT – La substitution de composants peut compromettre la securite intrinseque. (Reférez-vous au schéma 3).



WARNING – Fire Hazard

To prevent ignition of flammable or combustible atmospheres, disconnect power before servicing.

AVERTISSEMENT – Risque d’incendie

Pour éviter l’inflammation d’atmosphères inflammables ou combustibles , débrancher l’alimentation avant l’entretien.



WARNING – Sensor is not galvanically isolated, install according to NEC or CEC as required by your local regulations.

AVERTISSEMENT – Le capteur n’est pas isolé , installer selon NEC ou CEC tel que requis par les réglementations locales.

2. DESCRIPTION

The IQ Power HL Sensor is an electrostatic field measuring device packaged with a small form-factor. This makes the sensor suitable for use in plastic film and web processing applications. It can monitor processed materials for the presence, polarity and intensity of electrostatic charges. This allows for detection of the undesirable condition of excess static electricity and operation in CLFB (Closed-Loop Feed Back) mode with additional static neutralizing hardware.

The IQ Power HL Sensor is agency approved for mounting within hazardous locations:

Ex ia IIA T4 Ga

Class I, Division 1, Group D

Temperature Code T4, $T_a = 0^{\circ}\text{C}$ to 40°C

Each IQ Power HL Sensor must be connected to a pair of (user supplied) Intrinsic Safety Barriers to maintain hazardous location approval. One of the Intrinsic Safety Barriers provides protection for the circuit powering the sensor. The other Intrinsic Safety Barrier provides protection for the digital communication circuit of the sensor. Barriers must be compatible with device parameters as stated in Control Drawing 5150010.

The IQ Power HL Sensor interfaces with the IQ Power system through an IQ Power Sensor Interface. The IQ Power Sensor Interface provides connection for up to eight (8) IQ Power HL Sensors and connects to the IQ Power system through a convenient modular cable. The interface also provides indicators for sensors connected and overall system status. The IQ Power Sensor Interface and Intrinsic Safety Barriers must be located outside the hazardous area, see Figure 3, Control Drawing 5150010.

The IQ Power HL Sensor may be integrated with an IQ Power system to provide closed-loop feedback (CLFB) control of static elimination. This provides for better neutralization of static charges. Closed loop control will minimize troublesome under-compensation and over-compensation often found in simple (open loop) static neutralizing applications. Sensing charge on processed material also has the benefit of monitoring static neutralizer performance. If static charge on processed material becomes excessive, it could be an indication of service needed at the static neutralizing bar.

Static charge may not be readily apparent on processed materials. The IQ Power HL Sensor makes the intangible tangible, by providing hard data about electrostatic charges on processed materials. The sensor itself uses field sensing technology that provides accurate and long term stability of static field measurement. A further benefit of this technology is freedom from zero drift in the measurement.

3. SPECIFICATIONS

Input Power	24 VDC, 30 mA nominal
Input Connection	Via (user supplied) Intrinsic Safety Barriers (ref. Control Drawing 5150010)
Input Cable Lengths	30 ft (9.1m)
Input Purge Gas	(for minimizing dust, dirt and contamination in probe aperture only) 1 to 2.5 psi (7 to 17 kPa) nominal operating pressure 5 psi (35 kPa) max operating pressure 0.14 scfm (4 NL/min) per sensor at 1 psi (5 kPa) 0.22 scfm (6 NL/min) per sensor at 2.5 psi (20 kPa) Clean, dry, oil-free compressed air or nitrogen
Gas Input Connection	¼" OD Tubing, Quick Disconnect
Operating Temperature	40° C [104° F] max
Operating Humidity	70% RH max, no dewing permissible
Operating Distance*/Voltage	2" (50 mm) 20 kV max 3" (75 mm) 25 kV max 4" (100 mm) 30 kV max (factory default setting) 6" (150 mm) 40 kV max 8" (200 mm) 50 kV max 10" (250 mm) 60 kV max
Dimensions	260L x 32.5W x 44.5H mm [10.25"L x 1.28"H x 1.75"H]
Weight	0.68 kg [1.5 lb]
Enclosure	Stainless Steel and Conductive Polyamide
Mounting Hardware	Zinc plated metal perforated strip, stainless steel hardware

*Note: the operating distance set for sensor in control station must be the same as mounting distance sensor to web. This is critical for accurate calibration.

4. INSTALLATION

Unpacking

Carefully remove all equipment from its carton and inspect contents:

- Check that details on packing slip correspond to details of product received.
- Check that equipment is free from damage.
- If any damage has occurred during shipment, notify local carrier at once. A report should also be forwarded to Simco-Ion, 2257 North Penn Road, Hatfield, PA 19440. See Section 9 of this manual for Return Shipment information.

Mechanical Installation



NOTE – Conductive machine parts or a static neutralizing bar in vicinity of static sensor may have an undesired influence on its operation. For optimum results in CLFB, static sensor must be installed as per Figure 2.

1. Downstream of static neutralizing bar, at a minimum distance of 12” (300 mm) from static neutralizing bar so that any electric fields from static neutralizing bar will not interfere with charge measurement.



NOTE – For CLFB applications, **DO NOT** mount sensor upstream of a static neutralizing bar. Sensor must be mounted downstream of static neutralizing bar, see Figure 2.

2. Install at an optimum distance from material to be measured. Mounting distance is related to maximum static charge anticipated. The higher the anticipated charge, the further the sensor should be mounted from material. If the input range of the sensor is exceeded, the sensor will saturate and read the maximum. This does not cause damage to the sensor. The factory default mounting distance of 4” (100 mm) will provide an operating range of +/-30 kV.

Other operating distances and maximum operating ranges are:

- 2” (50 mm) 20 kV
- 3” (75 mm) 25 kV
- 4” (100 mm) 30 kV (factory default setting)
- 6” (150 mm) 40 kV
- 8” (200 mm) 50 kV
- 10” (250 mm) 60 kV



NOTE – Calibration of static sensor is distance dependent. If a distance other than the factory default setting is used, the Mounting Distance setting will need to be changed at IQ Power Control Station.

3. Sensors must face material to be measured and be perpendicular to surface.
4. **DO NOT** mount sensor over a roller or where material to be measured is in contact with any other surface. Nearby metal reduces sensor readings by capturing electric field lines.



NOTE – SENSITIVE ELECTRONICS: Risk of equipment damage.

Do not install sensor with charged materials present.

Sensor must already be connected to system in presence of charged materials.



NOTE – SENSITIVE ELECTRONICS: Risk of equipment damage.

Avoid sharp blows to sensor. Dropping sensor may cause damage to sensor element.

Sensor should be mounted on a structure that is free of vibration.

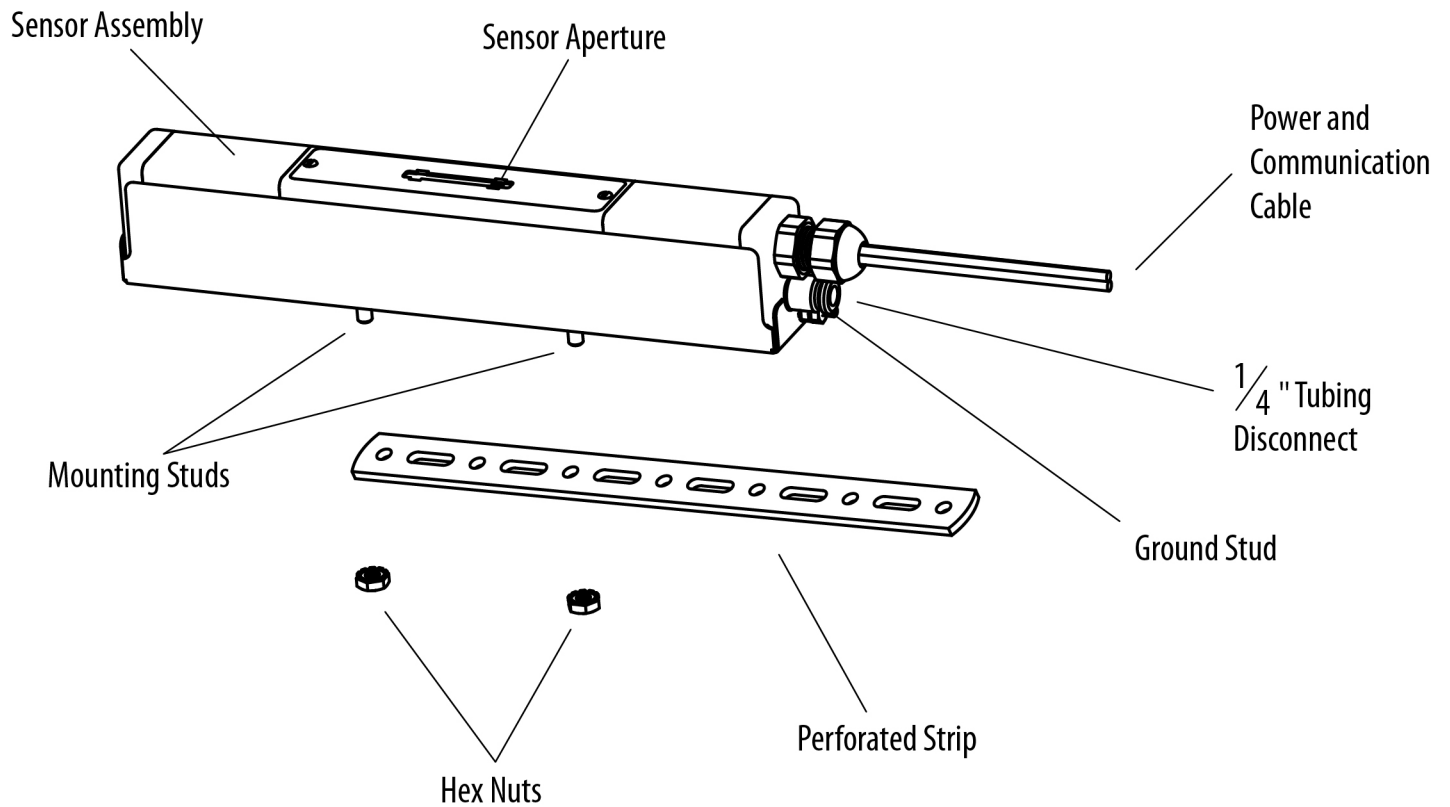

Figure 1. IQ Power HL Sensor Mounting

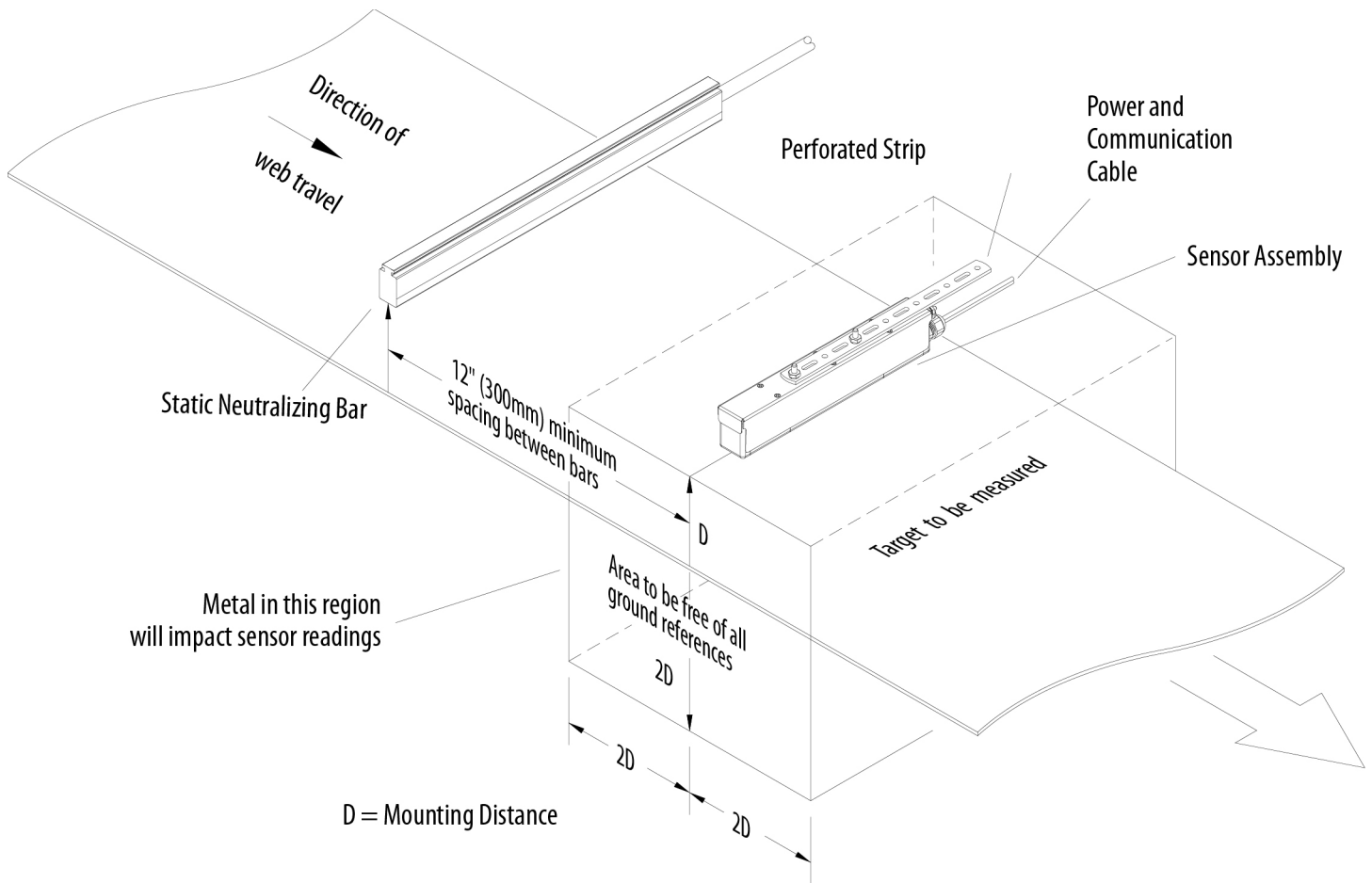

Figure 2. IQ Power HL Sensor Positioning (downstream of neutralizing bar)

5. Attach sensor assembly using perforated mounting strip and hardware supplied. The perforated strip may be bent or twisted prior to installation, if necessary. See Figures 1 and 2.
6. Secure perforated mounting strip to a machine frame or user supplied mounting means.
7. Install ground jumper to ground stud and connect to machine frame ground.
8. Route sensor cable away from any moving machine parts and out of the hazardous area. Secure cable to prevent damage.

Intrinsic Safety Barriers

Mount Intrinsic Safety Barriers (not included) between IQ Power HL Sensor and Sensor Interface. The barriers must meet requirements in the Control Drawing 5150010. Barriers must be mounted outside hazardous area and installed according to the manufacturer's instructions packaged with barrier. Note that two barriers (of different ratings) are required for each sensor in the system.

Sensor Interface

Mount IQ Power Sensor Interface as per instructions included with unit. The interface must be mounted outside the hazardous area. The interface provides power from and communication with the IQ Power system (Control Station).

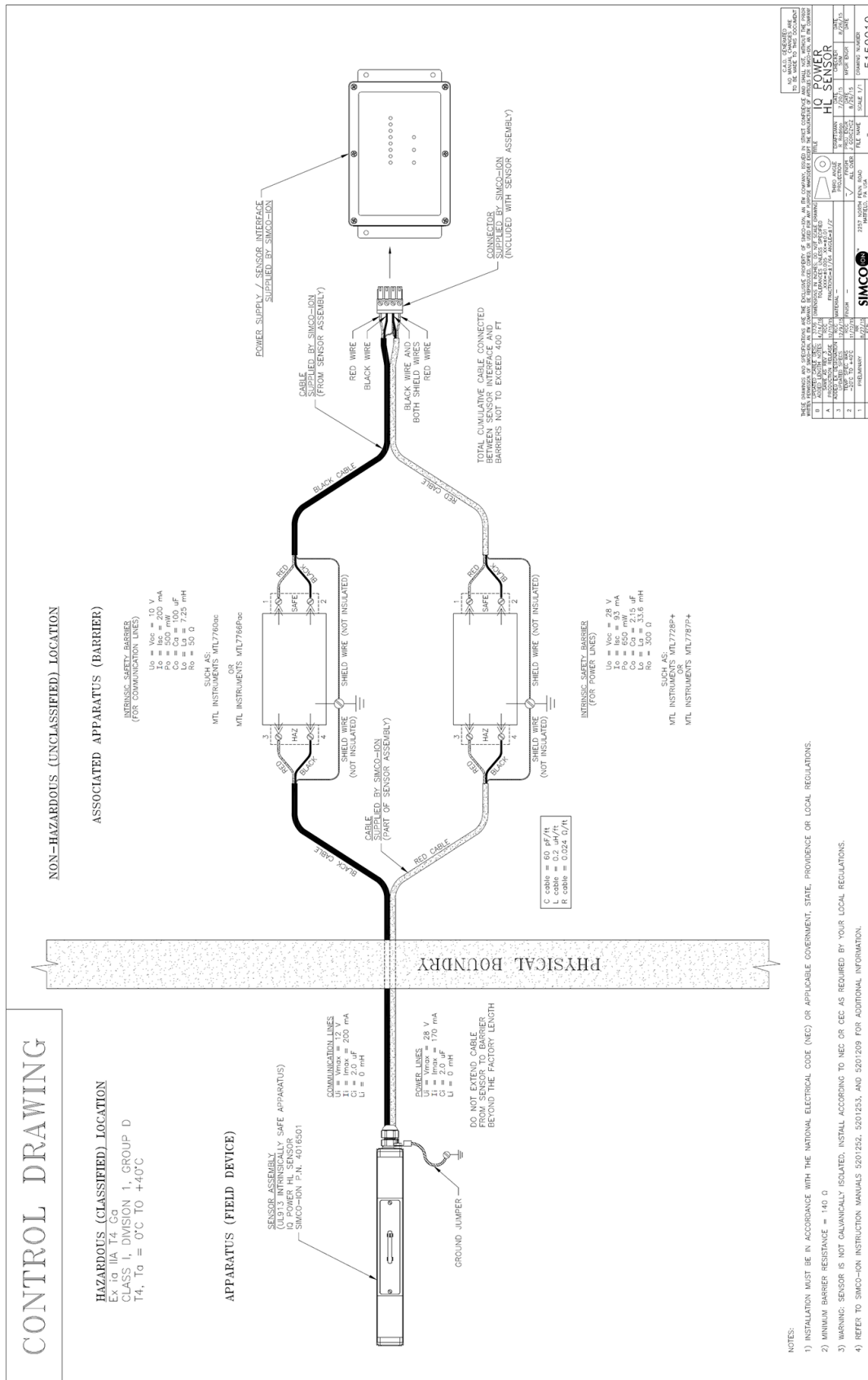

Figure 3. IQ Power HL Sensor Control Drawing 5150010



NOTE – Turn line voltage power off at IQ Power Control Station before connecting / disconnecting any devices. This is to avoid potential equipment failure and ensure proper digital communication.

1. Ground IQ Power HL Sensor by connecting ground lead between ground terminal on end of sensor assembly and a good electrical machine ground.

2. Connect sensor to Intrinsic Safety Barriers. Cut sensor cable to length at barriers allowing enough excess to make connections with barriers. **NOTE:** Best practice is to shorten cable as much as practical to provide best possible digital signal integrity. (DO NOT discard remaining cable as it will be used to connect barriers to Sensor Interface).

Split twin cable from sensor approximately 6” (150 mm). Carefully remove 4” (100 mm) of jacket from each cable. Remove foil shield and trim off, using care not to cut bare ground wire.

Strip red and black wires as required by barrier manufacturer for connection to barrier. Connect each cable to the HAZ side of the appropriate barrier; see Figure 3, Control Drawing 5150010. Note that one cable from sensor has a red jacket; this is the cable that carries power to the sensor. The other cable, with a black jacket, carries digital communications to and from the sensor.

3. Connect Intrinsic Safety Barriers to Sensor Interface using remnant of sensor cable from above step.

Split twin cable approximately 6” (150 mm). Carefully remove 4” (100 mm) of jacket from each cable. Remove foil shield and trim off, using care not to cut bare ground wire. Strip red and black wires as required by the barrier manufacturer for connection to the barrier. Connect each cable to the SAFE side of the appropriate barrier; see Figure 3, Control Drawing 5150010.

Split the twin cable approximately 4” (100 mm). Carefully remove 2” (50 mm) of jacket from each cable. Remove foil shield and trim off, using care not to cut bare ground wire. Strip red and black wires ¼” (6-7 mm) and connect to Sensor Port terminal block on Sensor Interface.

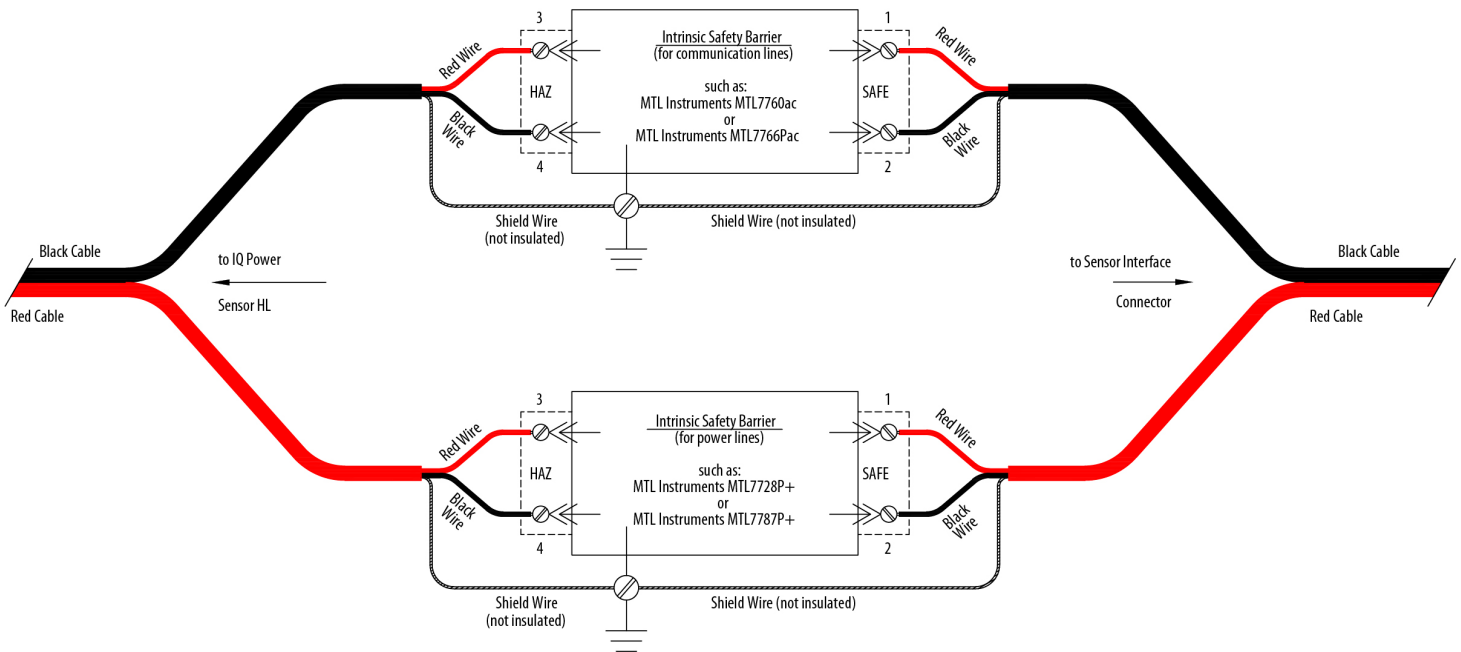

Figure 4. Safety Barrier Wiring

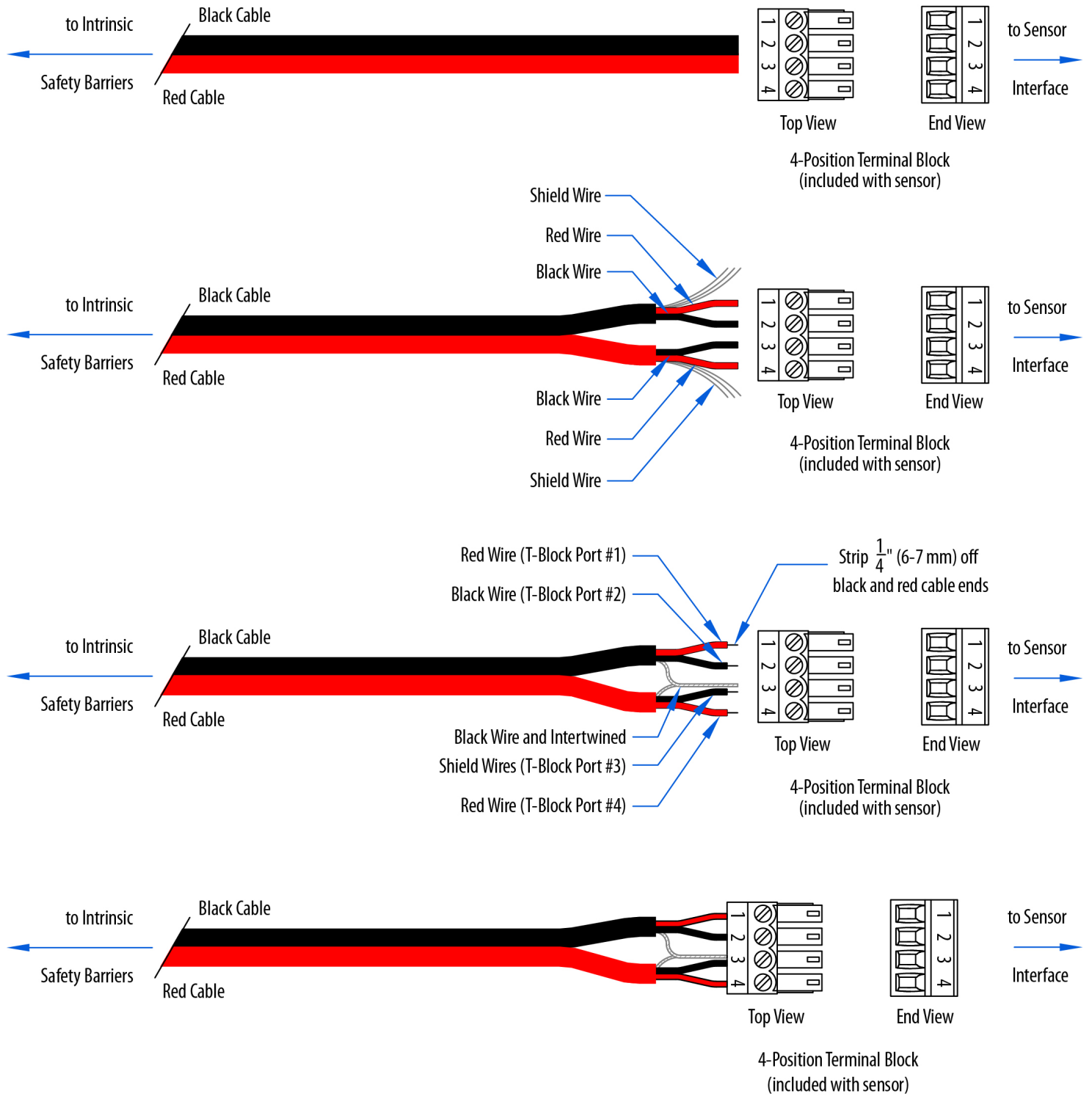

Figure 5. IQ Power HL Sensor Terminal Block Wiring

4. Connect Sensor Interface to IQ Power system (Control Station) using modular cable according to instructions included with the interface.

Purge Gas



NOTE – Purge gas or compressed air used with this device **MUST** be clean and dry. Dirt, water or oil in the purge gas will damage sensor. If the installation location is prone to surface contamination (such as a coating line) the use of purge gas is mandatory to maintain sensor operation.

In dirty or dusty environments low pressure purge gas may be used to prevent sensors from becoming fouled with debris. The purge system is designed to provide a gentle flow of purge gas at each sensor aperture where the electrostatic field is measured.

In environments with aerosol or vaporous contaminants (substances that tend to create a film on surfaces) purge gas **MUST** be used. Purge gas prevents fouling of the sensor element which will cause failure of the sensor.

The purge gas must be prepared with filtration and pressure regulation to ensure a low pressure flow of clean, dry, oil-free air. Operation of the purge system calls for purge gas at 1 to 2.5 psi (7 to 17 kPa). Connection to sensor bar is made with a ¼” outside diameter tubing quick disconnect. Tubing must be clean and may include typically used tubing materials such as nylon, polyethylene or polyurethane. To connect sensor assembly, make sure tubing is cut cleanly and not at an angle, then simply push tubing into fitting on end of bar.



NOTE – Do not apply more than 10 psi (70 kPa) to the purge gas fitting or equipment damage may result.

Route tubing away from any moving machine parts and secure tubing to prevent damage.

Sensor Number



NOTE – Do not plug two or more sensors with the same Sensor Number into the same Sensor Interface. Duplication of Sensor Numbers on an interface will cause unstable operation and corruption of data.

Each IQ Power HL Sensor is assigned a Sensor Number. The sensor number may be 1 through 8. The IQ Power HL Sensor comes from the factory with a label on its cable identifying its assigned Sensor Number.

The Sensor Number is used to identify the sensor and data associated with it. When the sensor is connected to an IQ Power Sensor Interface, an indicator will illuminate next to the corresponding Sensor Number. The Sensor Number will also appear on the Control Station display to indicate data received from that specific sensor and adjustments that may be made to that specific sensor.

In connecting sensors to a given IQ Power Sensor Interface, sensor numbers may **NOT** be duplicated. Connecting multiple sensors with the same Sensor Number to an interface will result in unstable operation and corruption of sensor reporting data.

Each sensor will light an indicator on the Sensor Interface that corresponds to its Sensor Number. If the total number of indicators lit does not match the quantity of sensors connected to the interface, check for a duplication of Sensor Numbers.

The Sensor Number is normally assigned at the factory and a label is applied to the cable end indicating Sensor Number. The Sensor Number may be changed in the field, see procedure 5201257.

Set Up

A variety of information can be checked and operating parameters set for the IQ Power HL Sensor through the IQ Power Control Station via the Sensor tab. Tap on the device icon for the sensor interface or neutralizer to access

these pages. Then tap on sensor tab for details about a particular sensor. To edit or select an operating parameter, tap on the pencil icon to right of parameter description.

Device Name: A user editable name to identify specific Sensor Interface.

Sensor Quantity: The number of sensors connected to sensor interface.

Mounting Distance: A user entered dimension, the spacing between face of sensor and web (surface being measured). The factory default mounting distance is 4" (100 mm).



NOTE – This information (Mounting Distance) **MUST** be correct. It is used by sensor for calibration. If this information is not correct, sensor calibration will be incorrect.

Average: The average web voltage of all sensors connected to interface. If the Sensor Interface is paired with a static neutralizer, the average for CLFB (Closed-Loop Feedback) will also be displayed.

Sensors for CLFB: If Sensor Interface is paired with a static neutralizer, sensors selected for CLFB will be displayed by their sensor number. The user selects these sensors.

Warning Setpoint: The web voltage level at which the sensor will set a “Warning” and display an alarm icon on Control Station display. The factory default value is 5kV, however this value may be user adjusted.

Fault Setpoint: The web voltage level at which the sensor will set an “Alarm” and display an alarm icon on Control Station display. The factory default value is 20kV, however this value may be user adjusted.

Web Voltage Sensor x: The web voltage from sensor “x”, where “x” is the sensor number.

Calibration Date Sensor x: The date sensor “x” was calibrated, where “x” is the sensor number also reports firmware revision in sensor assembly circuit board.

Up Time: The amount of time that sensor interface has been up and running.

Device Address: The address of Sensor Interface, a number 1 thru 10, used by Control Station to differentiate devices and also used to define association between devices.

Device Version: The firmware revision in interface circuit board.

Device Locator Utility: Causes indicator lights on the device (Sensor Interface) to flicker for a brief time to aid in verifying location of a given device.

Alarm Test Utility: Causes an alarm output to aid in checking / troubleshooting alarm sensing connections.

Closed-Loop Feedback (CLFB) Mode: The IQ Power HL Sensor can be used as part of a closed-loop feedback system to control an IQ Power Static Bar. In this configuration the ion output from the static bar is optimized to provide the best possible web neutralization. If the IQ Power HL Sensor is connected to the system through a static neutralizing power supply (HL or HLC & RDM), the sensor will automatically be paired with the neutralizer and a sensor tab will appear on the page for the neutralizer. Pairing may also be achieved manually by setting the setting the Sensor Interface Device Address to the same number as the neutralizer address. Setting the Operation Mode to CLFB (closed-loop feedback) is performed on the Static Bar device page, under the Neutralizer tab. In this operating mode, the static neutralizing bar **MUST** be upstream (before) the sensor.

5. OPERATION



NOTE – Before switching on power; ensure units are properly grounded and the Sensor, Isolation Barriers and Sensor Interface are all properly installed.

Operation of sensor is controlled through the IQ Power Control Station. In operation, a device icon appears on the IQ Power Control Station Home Page. Tapping on the device icon for the sensor interface or neutralizer enters a page with a tab containing information about each sensor. This includes descriptive information such as the device name and firmware revision levels. User inputs such as the sensor mounting distance (critical for correct calibration), warning and alarm set points, device name and add'l info. Output information includes web voltage for each sensor. Warning and alarm outputs are also included in these pages.

6. MAINTENANCE



WARNING – Fire Hazard

To prevent ignition of flammable or combustible atmospheres, disconnect power before servicing.

AVERTISSEMENT - Risque d'incendie

Pour éviter l'inflammation d'atmosphères inflammables ou combustibles, débrancher l'alimentation avant l'entretien.

Cleaning

Clean sensor assembly using a lint-free wiper moistened (but not saturated) with isopropyl alcohol. Use caution, and avoid contact with sensor aperture. Allow sensor to dry completely before applying power.

Calibration

Sensors should be calibrated to ensure accurate measurement. Calibration is performed at the factory or authorized service center. Recommended calibration interval is one year.

7. TROUBLESHOOTING



NOTE – Only qualified personnel are to perform troubleshooting tasks.

Problem	Cause	Solution
Power indicator on interface NOT illuminated	No supply voltage from Control Station	Turn on Control Station Change POWER & COMM connection at Control Station
	Wiring problem between interface and Control Station	Check wiring for cuts or breaks Check connectors for disconnection
Warning indicator on interface illuminated and a sensor number indicator is blinking*	Interface is in "Warning" (web voltage above Warning Setpoint)	Correct problem causing high web voltage Increase Warning Setpoint to eliminate nuisance warning
Fault indicator on interface illuminated and a sensor number indicator is blinking*	Interface is in "Alarm" (web voltage above Alarm Setpoint)	Correct problem causing high web voltage Increase Alarm Setpoint to eliminate nuisance alarms
Fault indicator on interface flickering (Comm indicator illuminated)*	Internal fault in interface	Cycle power to interface to see if fault clears
Fault indicator and a sensor number indicator on interface are flickering (Comm indicator illuminated)*	Wiring problem between sensor and interface	Check sensor wiring for cuts or breaks Check connectors for disconnection
	Problem with sensor module	Disconnect sensor and cycle power to verify if sensor is the problem Repair or replace defective sensor
Comm indicator on interface NOT illuminated	Wiring problem between interface and Control Station	Replace interface modular cable with known good cable
Incorrect number of Sensor indicators are illuminated on interface Ex: 3 sensors connected, only 2 Sensors LEDs lit.	Duplicate sensor numbers	Check sensor numbers for duplication. See 5201257 for changing sensor number

* If Warning or Alarm is activated, see Control Station and tap on Warning / Alarm icon for details.

8. PARTS AND ACCESSORIES

Part Description	Part Number
IQ Power HL Sensor	4016501
Perforated Mounting Strip	4750079
Connector Kit (Sensor to Interface)	5051864
Intrinsically Safe Barrier Kit	5051866
Red & Black Cable (for between Barrier and Interface ONLY)	4810324

9. WARRANTY AND SERVICE

This product has been carefully tested at the factory and is warranted to be free from any defects in materials or workmanship. Simco-Ion will, under this warranty, repair or replace any equipment that proves, upon our examination, to have become defective within one year from the date of purchase.

The equipment being returned under warranty should be shipped by the purchaser to Simco-Ion, 2257 North Penn Road, Hatfield, PA 19440, transportation prepaid and insured for its replacement cost. Prior to returning any goods for any reason, contact Simco-Ion Customer Service at (215) 822-6401 for a Return Authorization Number. This number must accompany all returned items.

This warranty does not apply when the equipment has been tampered with, misused, improperly installed, altered, has received damage through abuse, carelessness, accident, connected to improper line voltage, or has been serviced anyone other than an authorized factory representative.

The warranty does not apply when Simco-Ion parts and equipment have been energized by other than the appropriate Simco-Ion power supply or generator, or when a Simco-Ion power supply or generator has been used to energize other than Simco-Ion parts and equipment. Simco-Ion makes no warranty, expressed or implied, nor accepts any obligation, liabilities, or responsibility in connection with the use of this product other than the repair or replacement of parts stated herein.

Information in this publication supersedes that in all previous published material.

Specifications are subject to change without notice.

Simco-Ion

2257 North Penn Road
Hatfield, PA 19440

(215) 822-6401

(800) 203-3419

www.simco-ion.com

customerservice@simco-ion.com

© 2024 Simco-Ion. Printed in the U.S.A.