



IQ POWER HL STATIC BAR

INSTALLATION AND OPERATING INSTRUCTIONS

TABLE OF CONTENTS

1. SAFETY WARNINGS.....	1
2. DESCRIPTION	2
3. SPECIFICATIONS	3
4. INSTALLATION.....	4
Mounting the Static Neutralizing Bar	4
‘Y’ Sealing Fitting Installation.....	6
Conduit Requirements.....	7
5. MAINTENANCE	9
Cleaning the Static Bar	9
6. WARRANTY	10

1. SAFETY WARNINGS

For use in Hazardous Locations, Intrinsically Safe for use in:

Class I, Division I, Group D

Class II, Division I, Groups F and G

Class III, Division I

Temperature Code T4

Simco-Ion recommends that these instructions be read completely before installation or operation is attempted. Failure to do so could result in personal injury and/or damage to the equipment.



NOTE – Statements identified with NOTE indicate precautions necessary to avoid potential equipment failure.



CAUTION – Statements identified with CAUTION indicate potential safety hazards.



NOTE – This equipment must be correctly installed and properly maintained. Adhere to the following notes for safe installation and operation:

1. Read instruction manual before installing or operating equipment.
2. Only qualified service personnel are to perform installation and repairs.
3. All equipment must be properly grounded, including the machine frame to which the equipment is mounted.
4. Disconnect input power to the Power Supply before connecting or disconnecting static neutralizing bar or performing any maintenance to the system.



CAUTION – ELECTRICAL SHOCK HAZARD

Always disconnect power supply before connecting or disconnecting static neutralizing equipment. Avoid touching static neutralizing bar when power supply is energized.



CAUTION – FIRE HAZARD

Do not install or operate equipment in close proximity to any flammable solvents.

2. DESCRIPTION

The IQ POWER HL static bar is tailored to the application. Speed bars are optimized to operate on high speed webs at distances 2” to 9” [50 mm to 230 mm]. Hybrid bars are optimized to operate at 6” to 18” [150 to 460 mm] on webs where the web path is somewhat variable.

The static neutralizing bar features current limiting at each individual ion emitting pin to minimize the risk of hazardous electrical shock if the bar is touched while in operation or to eliminate the risk of explosion in specific classified areas. This safety feature does not compromise the IQ POWER HL bars ability to neutralize static charges.

The emitter pins are made of a special alloy to extend the longevity and sharpness of the points, providing optimal performance of the static bar.

The IQ POWER HL static bar is listed through ETL (Intertek) for both use in the United States and Canada, and is listed for intrinsically safe use in Class I, Division I, Group D, Class II, Division I, Groups F & G and Class III, Division I hazardous (classified) locations.

The IQ POWER HL static bar is designed to operate with a power supply having a maximum output of 10 kV_{PEAK} positive and 10 kV_{PEAK} negative. Refer to Section 4 for the proper mounting of the static bar. Refer to Figure 1 for static bar dimensional outline.

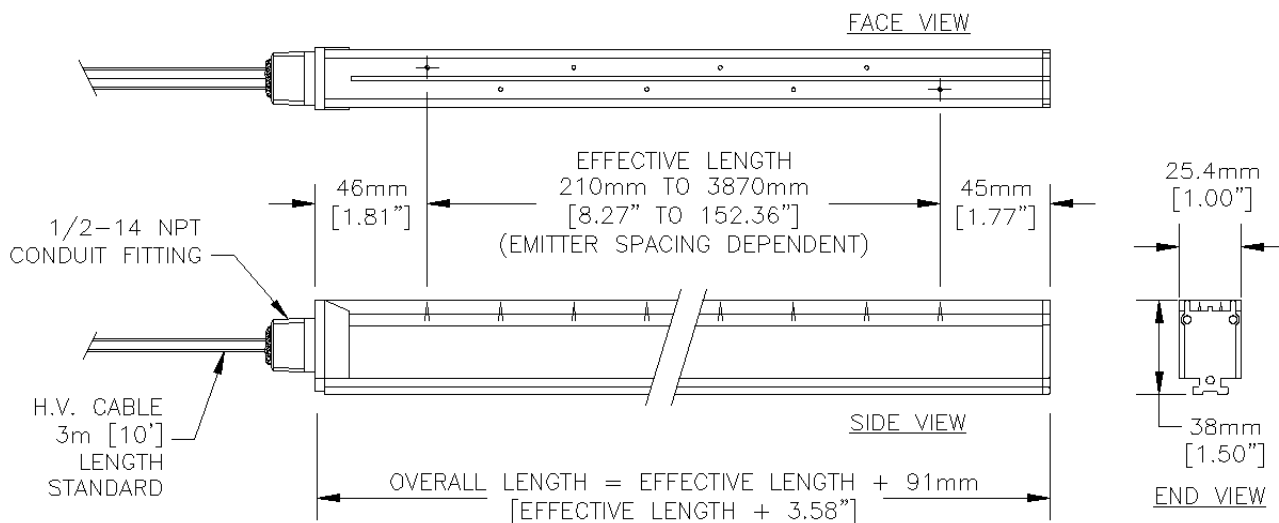

Figure 1. IQ POWER HL Static Bar

Table 1. Effective Length = (Number of Emitters -1) X Emitter Spacing			
Bar Type	Emitter Spacing (mm)	Emitter Spacing	
		Minimum	Maximum
Speed	30	8	130
Hybrid	90	8	44

Bars always have an even number of emitters.

3. SPECIFICATIONS

Operating Voltage	±9.5 kV _{PEAK} , max	
Nominal Bar Length (Overall Length)	Speed Bar: 11.85-55.95" [301-3961 mm] Hybrid Bar: 28.38-155.95" [721-961 mm]	Two bars per power supply
Dimensions	1.00"W x 1.93"H [26 W x 49 H]	
Weight	0.11 lb/in [1.8g/mm]	
Operating Temperature	32-176°F [T4/Ta 0-80°C]	
Humidity	80% RH max, no dewing permissible	
Enclosure	Glass-fiber-reinforced polyester	
Connection	½" NPT male thread at end of bar for metal conduit	
High Voltage Cable	10' [3m] standard / 90' [27.43m] maximum	
Emitter Material	Proprietary alloy specially selected to extend pin life	
Emitter Current	50 mA per emitter, max	
Emitter Spacing	Speed Bar: 1.18" [30 mm] Hybrid Bar: 3.54" [90 mm]	
Operating Distance	Speed Bar: 2-9" [50-230 mm] Hybrid Bar: 6-18" [150-460 mm]	
Installation Hardware	Plastic mounting brackets, metal perforated strips and stainless steel hardware (screws, nuts, and washers)	
Approval	CE	



CAUTION – Intrinsically Safe, Sécurité Intrinsèque for use in the following Hazardous Locations (Class I, Division I, Group D, Class II, Division I, Groups F and G, Class III, Division I).

Table 2. Typical Bar Loading Capacity

Total Effective Length of Bar	Maximum Total Conduit Length Per Bar
Up to 50" [1270 mm]	90' [27.43m]
51-100" [1295-2540 mm]	80' [24.38m]
101-125" [2565-3175 mm]	75' [22.86m]
126-150" [3200-3810 mm]	70' [21.33m]
151-200" [3835-5080 mm]	60' [18.29m]
201-250" [5105-6350 mm]	50' [15.24m]
251-275" [6375-6985 mm]	45' [13.72m]
276-312" [7010-7924 mm]	40' [12.19m]

4. INSTALLATION

The static bar is supplied with a mounting kit which contains “Blue” plastic mounting brackets, perforated strips, hardware, and set screws (Figures 2 and 3).

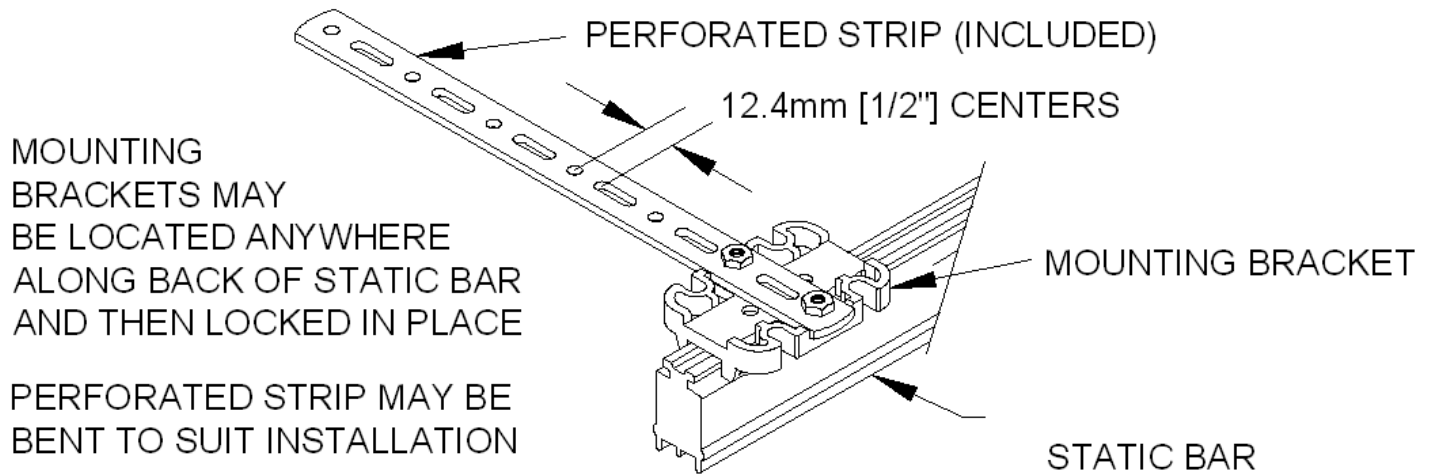

Figure 2. Static Bar Mounting Kit

Mounting the Static Neutralizing Bar

1. Determine the best location to mount the static neutralizing bar. The static bar will typically be located just ahead of where problems due to static are occurring. A static audit by a Simco-Ion representative can determine the best location of the static bar.
2. The appropriate operating distance. “R” (Figure 3) for the static bar is in part determined by the application:
 - a. **Speed Bars** (emitter point spacing 30 mm) are mounted closer to the web, 2” to 9” [50 mm to 230 mm] and may be installed in more congested areas of the machine; however the web path should be fixed for the speed bar. Optimum mounting distance for high speed webs is 4” [100 mm]. Speed bars can be identified by an ion emitter spacing of 1.18” [30 mm].
 - b. **Hybrid Bars** (emitter point spacing 90 mm) are mounted at a distance to the web, 6” to 18” [150 mm to 460 mm] and are usually installed where the web path is relatively free of obstructions. The benefit of Hybrid bars is that they allow mounting where the web path may be variable. Hybrid bars can be identified by an ion emitter spacing of 3.54” [90 mm].

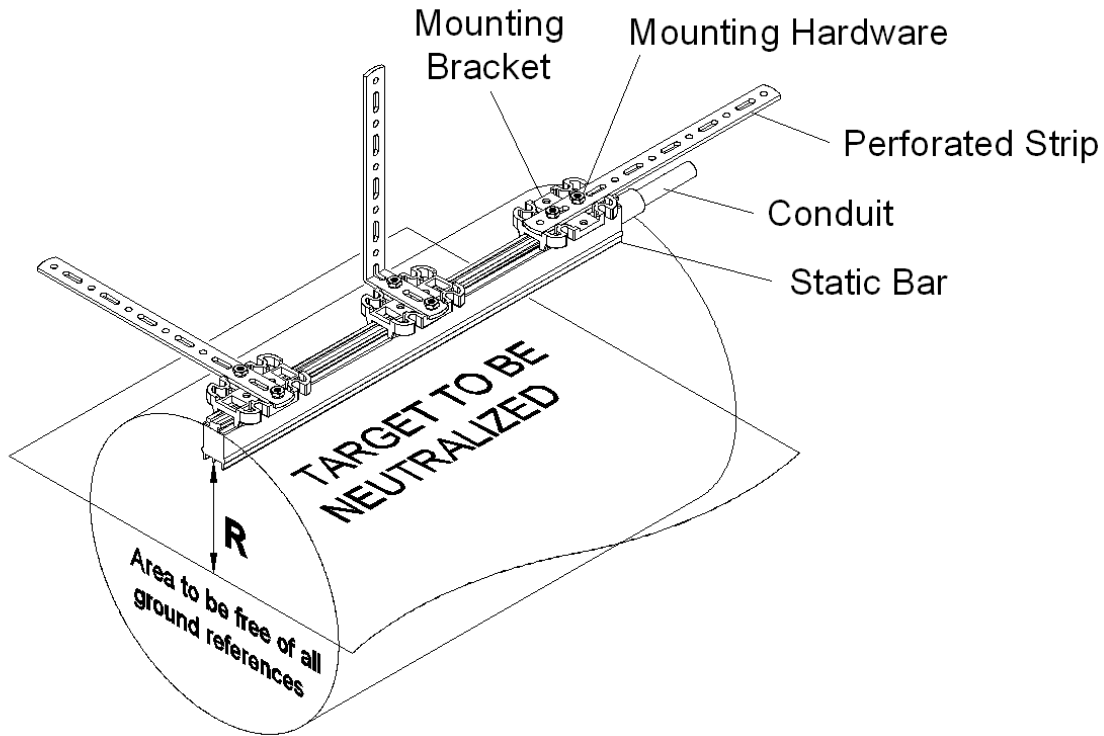

Figure 3. Static Bar Mounting Location



NOTE – IQ POWER HL bars should NOT be installed or operated at distances less than the minimum distance specified for the particular bar. (Speed 2” [50 mm] or Hybrid 6” [150 mm])



NOTE – The “free area” between the static bar and the web should have approximately equal height and width.



NOTE – There should be **NO** grounded metal such as an idler roller immediately behind the web on the far side from the static bar. The area behind the static bar should be as free as possible from grounded metal. Refer to Figure 4.

The effectiveness of the IQ POWER HL static bars is determined by the distance to the web and the speed that the web is moving. If the static bar is not performing adequately at a given distance, it may be necessary to reduce or increase the operating distance accordingly. **DO NOT** exceed the minimum operating distance of the particular bar though.

3. Install the bar to the conduit and carefully feed the high voltage cable through the conduit, making sure not to overly twist the high voltage cable and nick the cable insulation.

4. Locate the “Blue” plastic mounting brackets and slide them onto the “T” channel on the back of the static bar. Refer to Figure 2.

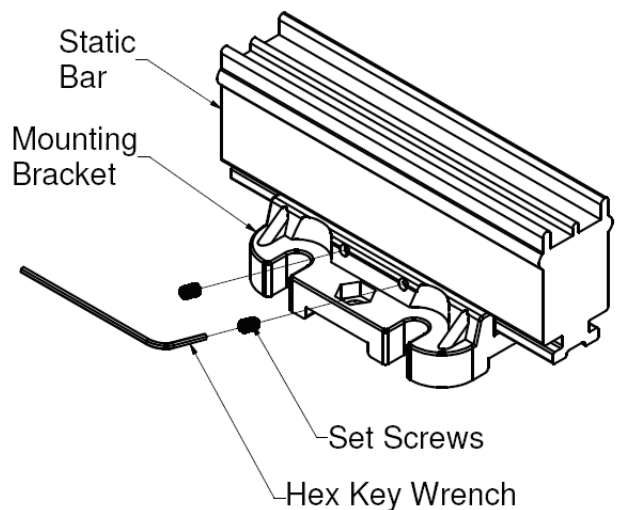

Figure 4. Securing the Static Bar

5. The perforated mounting strip may be installed on the mounting bracket at a right angle or parallel to the static bar. The perforated strip may be bent or twisted to suit the application and will hold its shape as installed.
6. Once the static bar is loosely installed, tighten all the remaining hardware.
7. Locate the set screws and the hex key wrench and install two (2) set screws into the holes in the side of the mounting bracket. The set screws engage the “T” slot on the back of the bar securing it in place (Figure 4).

‘Y’ Sealing Fitting Installation

The IQ POWER HL static bar requires the use of a “Y” conduit sealing fitting between the static bar and the physical boundary of the classified area. The high voltage wiring from the IQ POWER HL static bar must be properly prepared to ensure the sealing at the “Y” fitting(s). Refer to Figure 9 for a typical location.

1. Determine the location of the “Y” sealing fitting.
2. The high voltage wire from the IQ POWER HL static bar should be located in the conduit as it will be installed. This will prevent unnecessary twisting of the cable when the static bar is screwed to the conduit which could cause a failure of the cable.
3. Strip 1¾” (1.75” [45 mm]) length of the black PVC jacket to expose the two high voltage cables. Be careful not to nick the white plastic insulation on the high voltage cables.

NOTE – It is recommended to practice stripping off the jacket on the waste end of the high voltage cable prior to preparing the cable. This will minimize the risk of nicking or cutting the white high voltage insulation.

4. Separate the high voltage wires as shown in Figure 7.
5. Install the “Y” sealing fitting onto the conduit and tighten.

NOTE – The “Y” sealing fitting must be secured to the conduit with a minimum of 5 full turns.

6. Install the packing fiber generally following the “Y” sealing fitting manufactures; instructions while maintaining the high voltage wire separation. Refer to Figures 7 and 8.
7. Continue assembling the “Y” sealing fitting using the fitting manufacturers’ instructions regarding the sealing compound preparation, installation and curing.
8. Install the close-up plug and tighten completely.

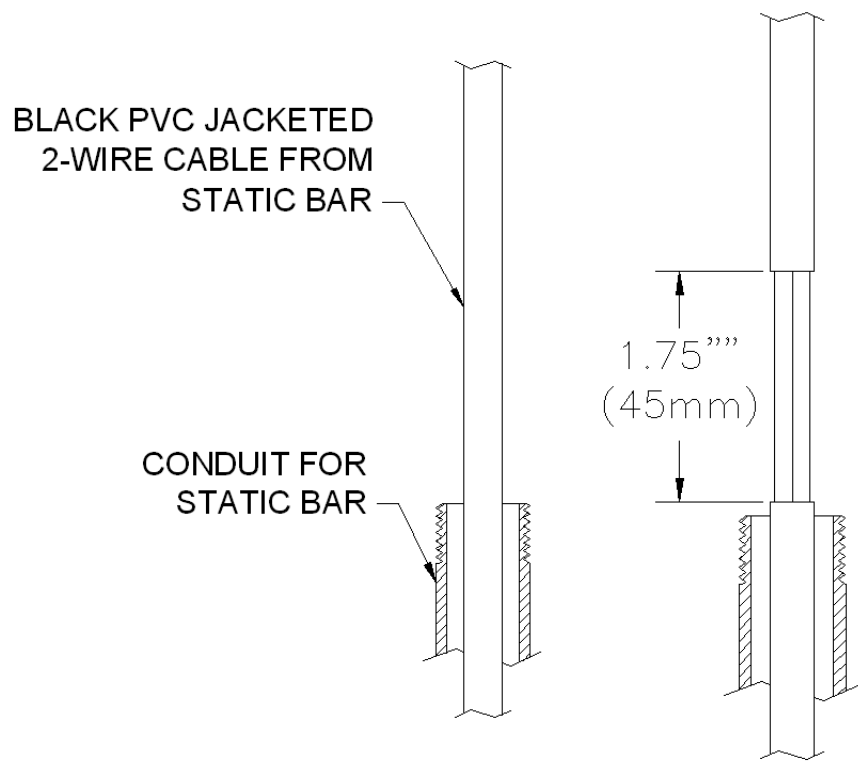

Figure 5

Figure 6



NOTE – The “Close-Up” plug must be secured to the “Y” sealing fitting with a minimum of 5 full turns.

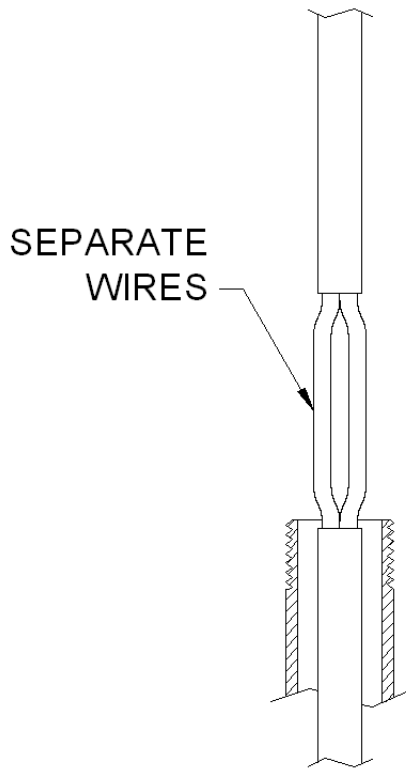

Figure 7

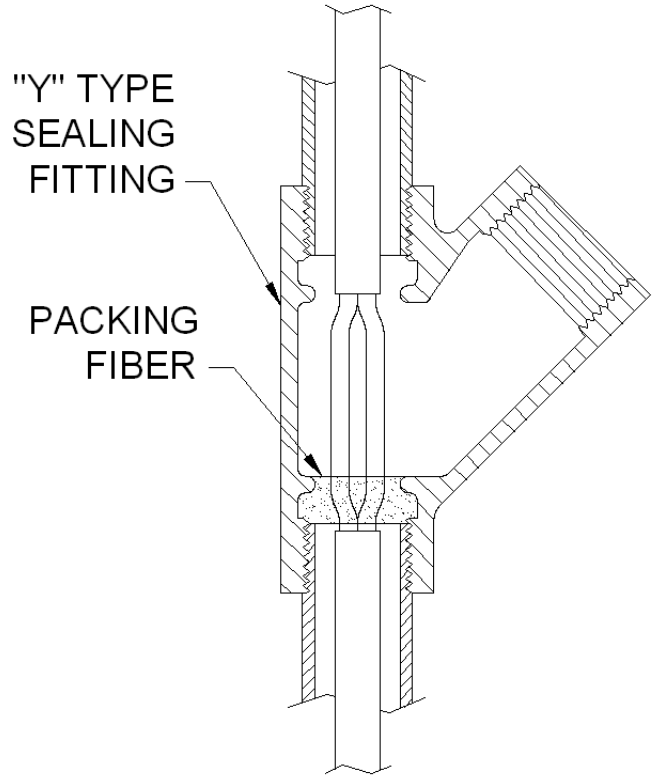

Figure 8

Table 3. Recommended “Y” Sealing Fitting

Table 3. Recommended “Y” Sealing Fitting	
Fitting	Adalet XY-2, 25% Fill, ½” NPT Female Threads
Packing Fiber	Adalet ADACO XAF-6
Sealing Cement	Adalet ADACO No. 1

Conduit Requirements



NOTE – It is the customer’s responsibility to provide approved conduit material installed in accordance with the National Electrical Code, (NEC) or any government, state, providence or local regulations.

1. All conduit and fittings must be approved for use in Class I, Division I, Group D, Class II, Division I, Groups F & G and Class III, Division I hazardous, (classified) locations.
2. The high voltage cable for the static bar must be installed in conduit. Each static bar has a ½” -14 NPT threaded fitting at the cable end of the bar.
3. A “Y” sealing fitting is required between the static bar and the boundary, (physical separation between the Class 1 location and the non-hazardous or unclassified area). Refer to Section 4 for the proper installation of the “Y” sealing fitting. Refer to Figure 9 for the typical location.

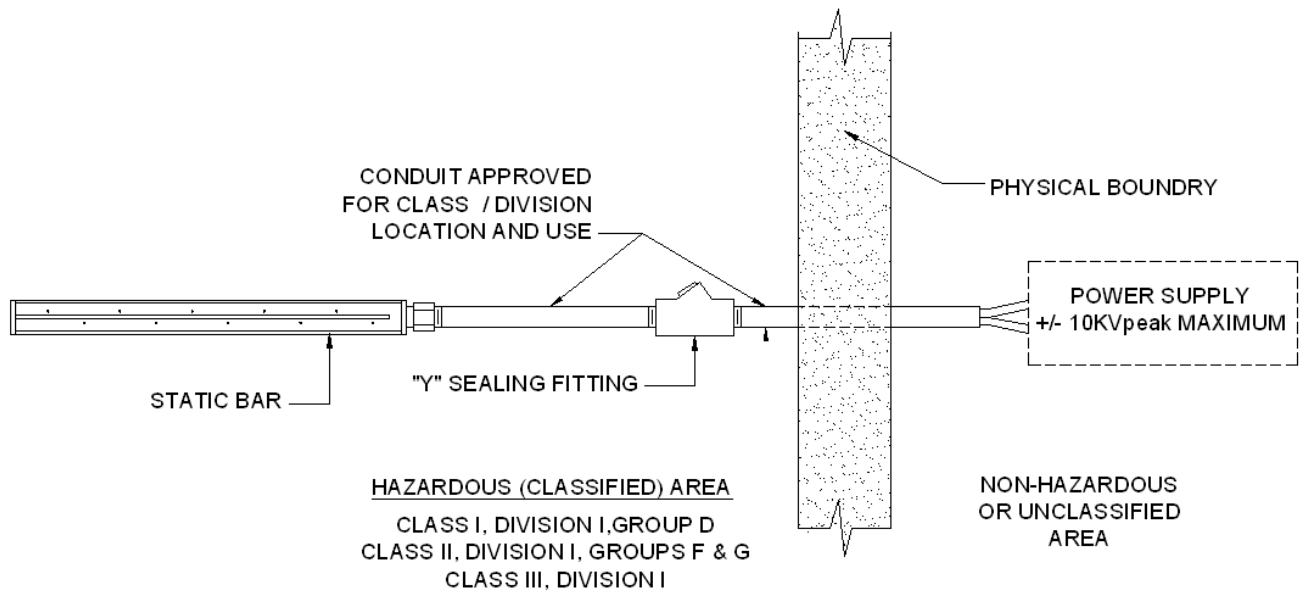

Figure 9. Conduit Requirements

5. MAINTENANCE



NOTE – Only qualified service personnel are to perform maintenance tasks.



CAUTION – Electrical Shock Hazard

Turn off Power Supply before cleaning bar or performing any maintenance on the system.

The accumulation of contamination on the ionization emitter points and static bar surfaces will reduce neutralizing efficiency of the bar, therefore it is recommended that maintenance of the system be performed when the Clean Bar indicator on the display module illuminates or every three weeks, whichever comes first. Dirty environments may require more frequent cleaning. Maintenance should be performed by qualified service personnel only.

Cleaning the Static Bar

A clean brush with nylon bristles should be used to keep the ionization emitter points of the static bar clean. Periodic use of the brush will prevent deposits from accumulating on the points. The emitter points must remain sharp for optimum operation.



NOTE – Do not scrape points with any hard or sharp object that may damage points.

1. Turn off power supply.
2. Remove dirt particles deposited on the static bar with a dry, stiff nylon bristle brush.
3. Blow off the static bar with clean, dry compressed air.
4. Remove resistant coatings deposited on static bar by wiping with isopropyl alcohol or mineral spirits applied to a clean cloth. Apply isopropyl alcohol or mineral spirits to a stiff nylon bristle brush and thoroughly scrub the ionization emitter channels of the bar.
5. Blow static bar dry with clean, dry compressed air and ensure the bar is completely dry before re-applying power to the bar.



NOTE – Do not soak static bar or related components in alcohol or mineral spirits. Do not use harsh solvents such as lacquer thinner, naphtha or acetone.

6. WARRANTY

This product has been carefully tested at the factory and is warranted to be free from any defects in materials or workmanship. Simco-Ion will, under this warranty, repair or replace any equipment that proves, upon our examination, to have become defective within one year from the date of purchase.

The equipment being returned under warranty should be shipped by the purchaser to Simco-Ion, 2257 North Penn Road, Hatfield PA 19440, transportation prepaid and insured for its replacement cost. Prior to returning any goods for any reason, contact Simco-Ion Customer Service at (215) 822-6401 for a Return Authorization Number. This number must accompany all returned items.

This warranty does not apply when the equipment has been tampered with, misused, improperly installed, altered, has received damage through abuse, carelessness, accident, connected to improper line voltage, or has been serviced anyone other than an authorized factory representative.

The warranty does not apply when Simco-Ion parts and equipment have been energized by other than the appropriate Simco-Ion power supply or generator, or when a Simco-Ion power supply or generator has been used to energize other than Simco-Ion parts and equipment. Simco-Ion makes no warranty, expressed or implied, nor accepts any obligation, liabilities, or responsibility in connection with the use of this product other than the repair or replacement of parts stated herein.

Simco-Ion
2257 North Penn Road
Hatfield, PA 19440

(215) 822-6401

(800) 203-3419

www.simco-ion.com

customerservice@simco-ion.com

© 2025 Simco-Ion Printed in the U.S.A.